

**CHAPTER 6**  
**SUPPORTING INFORMATION**

THIS PAGE WAS INTENTIONALLY LEFT BLANK

---

## SUPPORTING INFORMATION

### BOH PDM PORTABLE DRAWER MODULE OPERATION MANUAL (INCLUDING REPAIR PARTS & SPECIAL TOOL LIST) FOR 4 MODELS OF PDM MODULES BOH FPU Field Pack/up Units

#### INTRODUCTION TO MAINTENANCE ALLOCATION CHART (MAC)

---

#### INTRODUCTION

##### The BOH Environmental LLC recommended MAC

This introduction provides a general explanation of all maintenance and repair functions authorized at various maintenance levels under the standard Army Maintenance System concept.

The MAC (WP 0025 00, Table 1, immediately following the introduction) designates overall authority and responsibility for the performance of maintenance functions on the BOH PDM MODULES.

The application of the maintenance functions to the BOH PDM MODULES shall be consistent with the capacities and capabilities of the designated maintenance levels, which are shown on the MAC in column (4) as:

Unit – includes two sub columns, C (operator/crew) and O (unit) maintenance.

Direct Support – includes an F sub column.

General Support – includes an H sub column.

Depot – includes a D sub column.

The tools and test equipment requirements (WP 0025 00, Table 2, immediately following the MAC) list the tools and test equipment (both special tools and common tool sets) required for each maintenance function as referenced from the MAC.

#### Maintenance Functions

Maintenance functions are limited to and defined as follows:

1. **Inspect:** To determine the serviceability of an item by comparing its physical and mechanical characteristics with established standards through examination (e.g., by sight, sound, or feel). This includes scheduled inspections.
2. **Test:** To verify serviceability by measuring the mechanical characteristics of an item and comparing those characteristics with prescribed standards on a scheduled basis, i.e., load testing of lift devices and hydrostatic testing of pressure hoses.
3. **Service:** Operations required periodically to keep an item in proper operating condition; e.g., to clean (includes decontaminate, when required), to preserve, to drain, to paint, or to replenish fuel, lubricants, chemical fluids, or gases.
4. **Adjust:** To maintain or regulate, within prescribed limits, by bringing into proper position, or by setting the operating characteristics to specific parameters.

5. **Align:** To adjust specified variable elements of an item to bring about optimum or desired performance.
6. **Calibrate:** To determine and cause corrections to be made or to be adjusted on instruments of test, measuring, and diagnostic equipment used in precision measurement. Consists of comparisons of two instruments, one of which is a certified standard of known accuracy, to detect and adjust any discrepancy in the accuracy of the instrument being compared.
7. **Remove/Install:** To remove and install the same item when required to perform service or other maintenance functions. Install may be the act of emplacing, seating, or fixing into position a spare, repair part, or module (component or assembly) in a manner to allow the proper functioning of an equipment or system.
8. **Replace:** To remove an unserviceable item and install a serviceable counterpart in its place. "Replace" is authorized by the MAC and assigned maintenance level is shown as the third position code of the Source, Maintenance and Recoverability (SMR) code.
9. **Repair:** The application of maintenance services, including fault location/troubleshooting, removal/installation, disassembly/assembly procedures, and maintenance actions to identify troubles and restore serviceability to an item by correcting specific damage, fault, malfunction, or failure in a part, subassembly, module (component or assembly), end item, or system.

#### **NOTE**

The following definitions are applicable to the "REPAIR" maintenance functions of Service, Inspect, Test, Adjust, Align, Calibrate, and/or Replace:

Fault location/troubleshooting – The process of investigating and detecting the cause of equipment malfunctioning; the act of isolating a fault within a system or Unit Under Test (UUT).

Disassembly/Assembly – The step-by-step breakdown (taking apart) of a spare/functional group coded item to the level of its least component, that is assigned an SMR code for the level of maintenance under consideration (i.e., identified as maintenance significant).

Actions – Welding, grinding, riveting, straightening, facing, machining, and/or resurfacing.

10. **Overhaul:** That maintenance effort (service/action) prescribed to restore an item to a completely serviceable/operational condition as required by maintenance standards in appropriate technical publications. Overhaul is normally the highest degree of maintenance performed by the Army. Overhaul does not normally return an item to like new condition.
11. **Rebuild:** Consists of those services/actions necessary for the restoration of unserviceable equipment to a like new condition in accordance with original manufacturing standards. Rebuild is the highest degree of materiel maintenance applied to Army equipment. The rebuild operation includes the act of returning to zero those age measurements (e.g., hours/miles) considered in classifying Army equipment/components.

### Explanation of Columns in the MAC WP 0025 00

Column (1) – Group Number. Column (1) lists Functional Group Code (FGC) numbers, the purpose of which is to identify maintenance significant components, assemblies, subassemblies, and modules with the Next Higher Assembly (NHA).

Column (2) – Component/Assembly. Column (2) contains the item names of components, assemblies, subassemblies, and modules for which maintenance is authorized.

Column (3) – Maintenance Function. Column (3) lists the functions to be performed on the item listed in column (2). (For a detailed explanation of these functions refer to “Maintenance Functions” outlined above).

Column (4) – Maintenance Level. Column (4) specifies each level of maintenance authorized to perform each function listed in column (3), by indicating work time required (expressed as man-hours in whole hours or decimals) in the appropriate sub column. This work time figure represents the active time required to perform that maintenance function at the indicated level of maintenance. If the number or complexity of the tasks within the listed maintenance function varies at different maintenance levels, appropriate work time figures are to be shown for each level. The work time figure represents the average time required to restore an item (assembly, subassembly, component, module, end item, or system) to a serviceable condition under typical field operating conditions. This time includes preparation time (including any necessary disassembly/assembly time), troubleshooting/fault location time, and quality assurance time in addition to the time required to perform the specific tasks identified for the maintenance functions authorized in the MAC. The symbol designations for the various maintenance levels are as follows:

- **C – Operator or crew maintenance**
- **O– Unit maintenance**
- **F – Direct Support maintenance**
- **L – Specialized repair activity (SRA)**
- **H – General support maintenance**
- **D – Depot maintenance**

#### NOTE

The "L" maintenance level is not included in column (4) of the MAC. Functions to this level of maintenance are identified by a work time figure in the "H" column of column (4), and an associated reference code is used in the REMARKS column (6). This code is keyed to the remarks and the SRA complete repair application is explained there.

Column (5) – Tools and Equipment Reference Code. Column (5) specifies, by code, those common tool sets (not individual tools), common Test, Measurement and Diagnostic Equipment (TMDE), and special tools, special TMDE and special support equipment required to perform the designated function. codes are keyed to the entries in the tools and test equipment table

Column (6) – Remarks Code. When applicable, this column contains a letter code, in alphabetical order, which is keyed to the remarks table entries

### Explanation of Columns in the Tools and Test Equipment Requirements

Column (1) – Tool or Test Equipment Reference Code. The tool or test equipment reference code correlates with a code used in column (5) of the MAC.

Column (2) – Maintenance Level. The lowest level of maintenance authorized to use the tool or test equipment.

Column (3) – Nomenclature. Name or identification of the tool or test equipment.

Column (4) – National Stock Number (NSN). The NSN of the tool or test equipment.

Column (5) – Tool Number. The manufacturer's part number, model number, or type number.

Explanation of Columns in the Remarks (WP 0025 00, Table 3)

Column (1) – Remarks Code. The code recorded in column (6) of the MAC.

Column (2) – Remarks. This column lists information pertinent to the maintenance function being performed as indicated in the MAC.

**END OF WORK PACKAGE**

## SUPPORTING INFORMATION

### BOH PDM PORTABLE DRAWER MODULE OPERATION MANUAL (INCLUDING REPAIR PARTS & SPECIAL TOOL LIST) FOR 4 MODELS OF PDM MODULES BOH FPU Field Pack/up Units

#### MAINTENANCE ALLOCATION CHART (MAC)

(1) Group Number	(2) Component/Assembly	(3) Maintenance Function	(4) Maintenance Level					(5) Tools and Equipment Ref Code	(6) Remarks
			Unit		Direct Support	General Support	Depot		
			C	O	F	H	D		
00	PDM Module Systems								
01	PDM Module Configuration	INSPECT	0.1	0.1					
		SERVICE		0.2					
		ALIGN			0.5				
		REPLACE		1					
		REPAIR			1				
02	Drawer Module Assemblies	INSPECT	0.1	0.1					
		SERVICE		0.2					
		ALIGN			0.5				
		REPLACE		1					
		REPAIR			1				
0201	PDM Case	INSPECT	0.1	0.1					
		SERVICE		0.2					
		ALIGN			0.5				
		REPLACE		1					
		REPAIR			1				
0202	PDM Tray	INSPECT	0.1	0.1					
		SERVICE		0.2					
		ALIGN			0.5				
		REPLACE		1					
		REPAIR			1				



---

## SUPPORTING INFORMATION

### BOH PDM PORTABLE DRAWER MODULE OPERATION MANUAL (INCLUDING REPAIR PARTS & SPECIAL TOOL LIST) FOR 4 MODELS OF PDM MODULES BOH FPU Field Pack/up Units

#### INTRODUCTION TO REPAIR PARTS & SPECIAL TOOL LIST

---

#### INTRODUCTION

#### SCOPE

This Repair Parts & Special Tools List (PARTS LIST ) lists and authorizes spares and repair parts; special tools; special test, measurement, and diagnostic equipment (TMDE); and other special support equipment required for performance of Operator, Unit, and Direct Support maintenance of the BOH PDM MODULES.

It authorizes the requisitioning, issue, and disposition of spares, repair parts, and special tools as indicated by the Source, Maintenance, and Recoverability (SMR) codes.

#### GENERAL

In addition to the Introduction work package, this PARTS LIST is divided into the following work packages:

1. Repair Parts List Work Packages. Work packages containing lists of spares and repair parts authorized by this PARTS LIST for use in the performance of maintenance. These work packages also include parts which must be removed for replacement of the authorized parts. Parts lists are composed of functional groups in ascending alphanumeric sequence, with the parts in each group listed in ascending figure and item number sequence. Sending units, brackets, filters, and bolts are listed with the component they mount on. Bulk materials are listed by item name in FIG. BULK at the end of the work packages. Repair parts kits are listed separately in their own functional group and work package. Repair parts for reparable special tools are also listed in a separate work package. Items listed are shown on the associated illustrations.
2. Cross-Reference Indexes Work Packages. There are two cross-reference indexes work packages in this PARTS LIST : the National Stock Number (NSN) Index work package and the Part Number (P/N) Index work package. The National Stock Number Index work package refers you to the figure and item number. The Part Number Index work package refers you to the figure and item number.

#### EXPLANATION OF COLUMNS IN THE REPAIR PARTS LIST AND SPECIAL TOOLS LIST WORK PACKAGES

**ITEM NO.** (Column (1)). Indicates the number used to identify items called out in the illustration.

**NSN** (Column (3)). The NSN for the item is listed in this column.

**CAGEC** (Column (4)). The Commercial and Government Entity Code (CAGEC) is a five-digit code which is used to identify the manufacturer, distributor, or Government agency/activity that supplies the item.

**PART NUMBER** (Column (5)). Indicates the primary number used by the manufacturer (individual, company, firm, corporation, or Government activity), which controls the design and characteristics of the item by means of its engineering drawings, specifications, standards, and inspection requirements to identify an item or range of items.

### NOTE

When you use an NSN to requisition an item, the item you receive may have a different P/N from the number listed.

### DESCRIPTION AND USABLE ON CODE (UOC)

(Column (5)). This column includes the following information:

1. The federal item name, and when required, a minimum description to identify the item.
2. P/Ns of bulk materials are referenced in this column in the line entry to be manufactured or fabricated.
3. Hardness Critical Item (HCI). A support item that provides the equipment with special protection from electromagnetic pulse (EMP) damage during a nuclear attack.
4. The statement END OF FIGURE appears just below the last item description in column (6) for a given figure in both the repair parts list and special tools list work packages.

QTY (Column (6)). The QTY (quantity per figure) column indicates the quantity of the item used in the breakout shown on the illustration/figure, which is prepared for a functional group, sub-functional group, or an assembly. A "AR" (as required) appearing in this column instead of a quantity indicates that the quantity is variable and quantity may change from application to application.

### EXPLANATION OF CROSS-REFERENCE INDEXES WORK PACKAGES FORMAT AND COLUMNS.

1. National Stock Number (NSN) Index Work Package.

**STOCK NUMBER Column.** This column lists the NSN in National Item Identification Number (NIIN) sequence. The NIIN consists of the last nine digits of the NSN.

NSN  
(e.g.,5385-01-574-1476)

When using this column to locate an item, ignore the first four digits of the NSN. However, the complete NSN should be used when ordering items by stock number.

**FIG. Column.** This column lists the number of the figure where the item is identified/located. The figures are in numerical order in the repair parts list and special tools list work packages.

**ITEM Column.** The item number identifies the item associated with the figure listed in the adjacent FIG. Column. This item is also identified by the NSN listed on the same line.

2. Part Number (P/N) Index Work Package. P/Ns in this index are listed in ascending alphanumeric sequence (vertical arrangement of letter and number combinations which places the first letter or digit of each group in order A through Z, followed by the numbers 0 through 9 and each following letter or digit in like order).

**PART NUMBER Column.** Indicates the P/N assigned to the item.

FIG. Column. This column lists the number of the figure where the item is identified/located in the repair parts list and special tools list work packages.

ITEM Column. The item number is the number assigned to the item as it appears in the figure referenced in the adjacent figure number column.

### **SPECIAL INFORMATION**

UOC. The UOC appears in the lower left corner of the Description Column heading. Usable On Codes are shown as "UOC: . . ." in the Description Column (justified left) on the first line under the applicable item/nomenclature. None coded items are applicable to all models. Identification of the UOCs used in this PARTS LIST are: NOT ASSIGNED YET

Fabrication Instructions. Bulk materiel required to manufacture items are listed in the bulk materiel functional group of this PARTS LIST . Part numbers for bulk materiel are also referenced in the Description Column of the line item entry for the item to be manufactured/fabricated. Detailed fabrication instructions for items source Coded to be manufactured or fabricated are found in: Not Applicable.

Index Numbers Column. This index number is a cross-reference between the NSN and P/N index work packages and the materiel list in the repair parts list work package.

Associated Publications. The publication(s) listed below pertain to the BOH PDM MODULE SYSTEM:

<b><u>Publication</u></b>	<b><u>Short Title</u></b>
---------------------------	---------------------------

Illustrations List. The illustrations in this PARTS LIST contain unit and direct support authorized items. The tabular list in the repair parts list work package contains only those parts coded "O" and "F" in the third position of the SMR code, therefore, there may be a break in the item number sequence.

## HOW TO LOCATE REPAIR PARTS

### A. When NSNs or P/Ns Are Not Known.

1. Using the table of contents, determine the assembly group to which the item belongs. This is necessary since figures are prepared for assembly groups and subassembly groups, and lists are divided into the same groups.
2. Find the figure covering the functional group or the sub functional group to which the item belongs.
3. Identify the item on the figure and note the number(s).
4. Look in the repair parts list work packages for the figure and item numbers. The NSNs and part numbers are on the same line as the associated item numbers.

### B. When NSN Is Known.

1. If you have the NSN, look in the STOCK NUMBER column of the NSN index work package. The NSN is arranged in NIIN sequence. Note the figure and item number next to the NSN.
2. Turn to the figure and locate the item number. Verify that the item is the one you are looking for.

### C. When the P/N Is Known.

1. If you have the P/N and not the NSN, look in the PART NUMBER column of the P/N index work package. Identify the figure and item number.
2. Look up the item on the figure in the applicable repair parts list work package.

## ABBREVIATIONS

### Abbreviation

AY  
KT  
FPU- PDM  
AR

### Explanation

ASSEMBLY  
KIT  
FIELD PACK\_UP PDM MODULE  
AS REQUIRED

**END OF WORK PACKAGE**

**SUPPORTING INFORMATION**

**BOH PDM PORTABLE DRAWER MODULE OPERATION MANUAL  
(INCLUDING REPAIR PARTS & SPECIAL TOOL LIST)  
FOR 4 MODELS OF PDM MODULES  
BOH FPU Field Pack/up Units**

**PDM MODULER SYSTEMS**

---

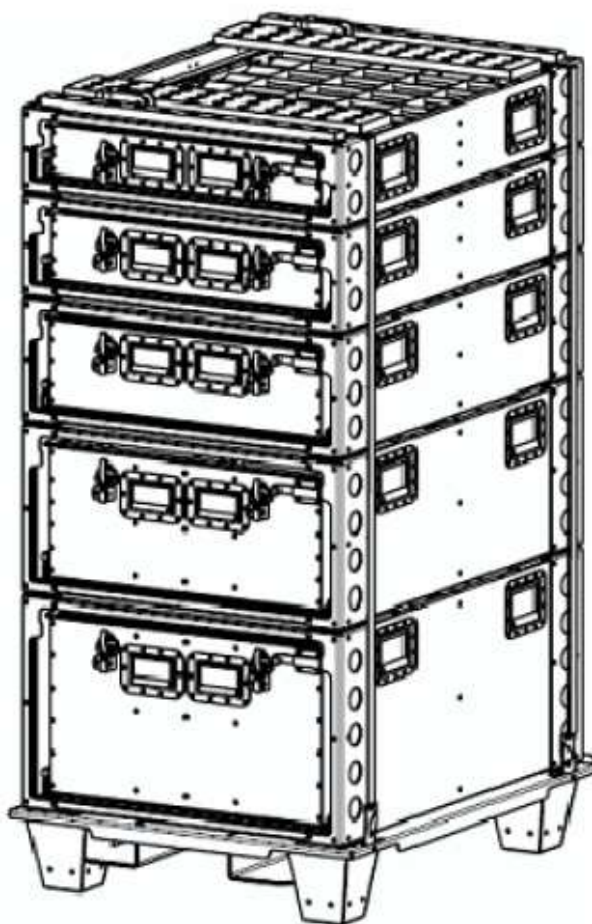

**PDM MODULER SYSTEMS**

**BOH PDM MODULE  
CONFIGURATIONS # 01 THRU # 04**

**PDM CONFIGURATION #1**

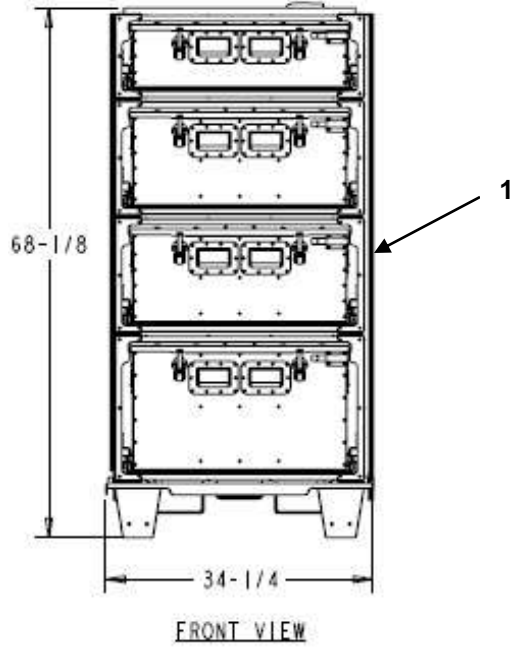

**PDM CONFIGURATION #2**

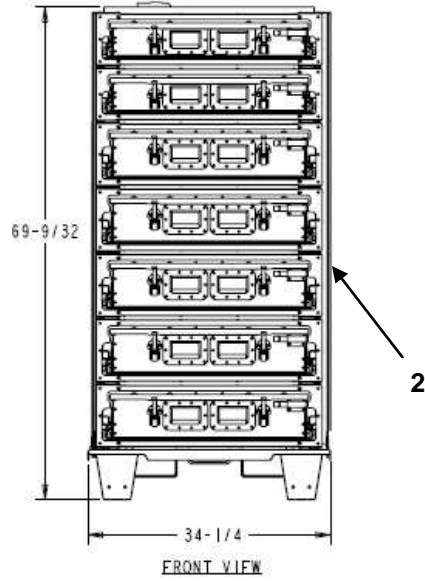

**PDM CONFIGURATION #3**

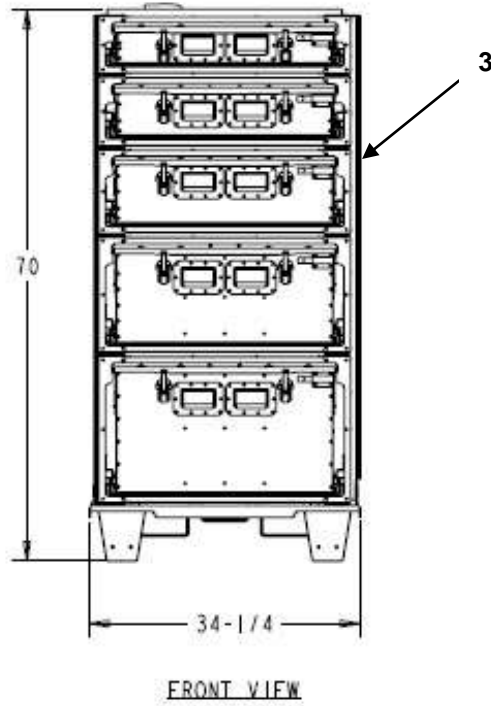

**PDM CONFIGURATION #4**

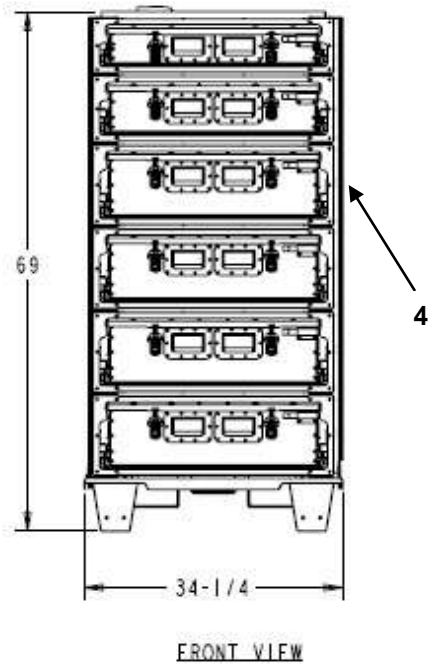

**FIGURE 01 PDM CONFIGURATIONS # 01 THRU # 04**

(1) ITEM NO.	(2) NSN	(3) CAGEC	(4) PART NUMBER	(5) DESCRIPTION AND USABLE ON CODE (UOC)	(6) QTY
				<b>GROUP 01 FIGURE 01 BOH PDM CONFIGURATIONS 01 THRU 04</b>	
1	8145-01-588-3672	1NSG3	15003201-001	BOH PDM MODULE CONFIG # 01 GREEN	1
1	8145-01-588-3672	1NSG3	15003201-002	BOH PDM MODULE CONFIG # 01 TAN	1
2	8145-01-588-3677	1NSG3	15003202-001	BOH PDM MODULE CONFIG #02 GREEN	1
2	8145-01-588-3677	1NSG3	15003202-002	BOH PDM MODULE CONFIG # 02 TAN	1
3	8145-01-588-3678	1NSG3	15003203-001	BOH PDM MODULE CONFIG # 03 GREEN	1
3	8145-01-588-3678	1NSG3	15003203-002	BOH PDM MODULE CONFIG # 03 TAN	1
4	8145-01-588-3688	1NSG3	15003204-001	BOH PDM MODULE CONFIG # 04 GREEN	1
4	8145-01-588-3688	1NSG3	15003204-002	BOH PDM MODULE CONFIG # 04 TAN	1
<b>END OF FIGURE 01</b>					

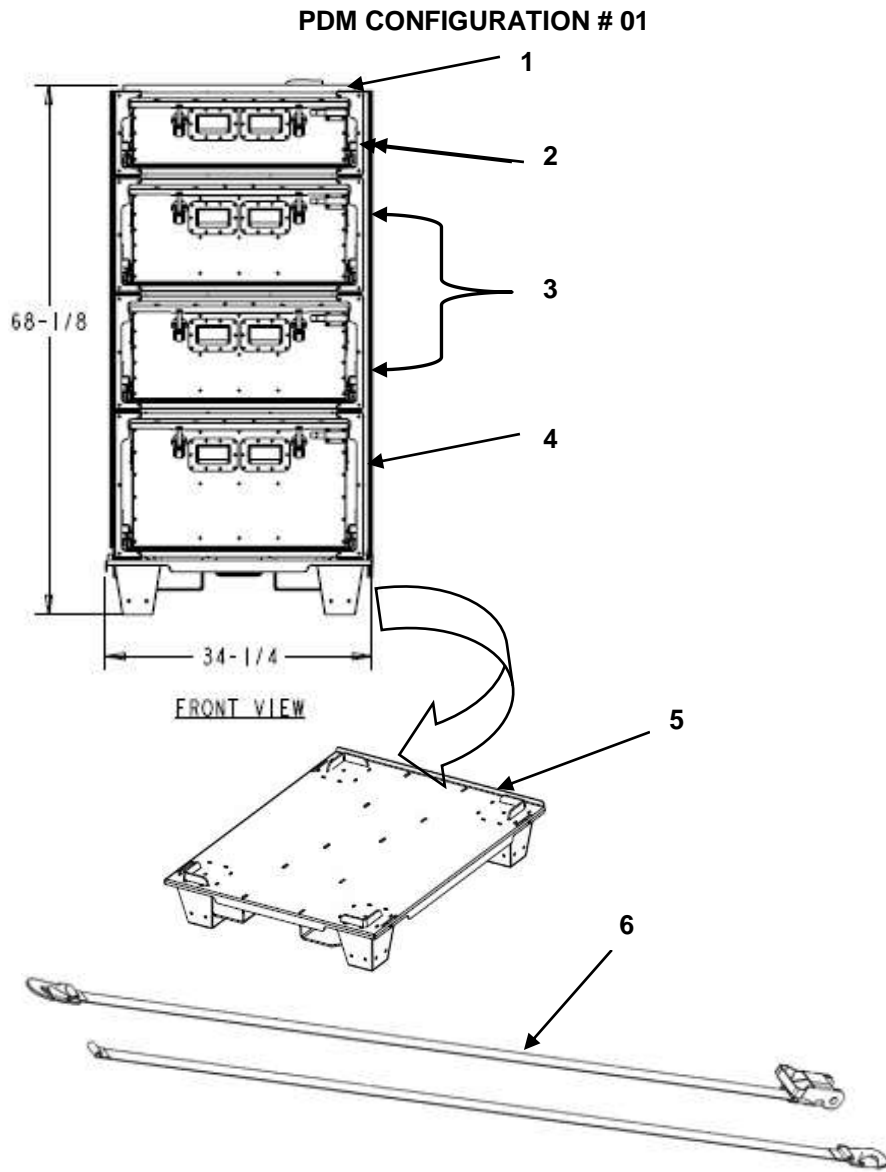

**FIGURE 02 PDM CONFIGURATION # 01**

(1) ITEM NO.	(2) NSN	(3) CAGEC	(4) PART NUMBER	(5) DESCRIPTION AND USABLE ON CODE (UOC)	(6) QTY
				<b>GROUP 0101 FIGURE 02 BOH PDM MODULE CONFIGURATION #01</b>	
1	8145-01-588-3672	1NSG3	15003201-001	.BOH PDM MODULE CONFIG # 01 GREEN	1
2	NOT ASSIGNED	1NSG3	16440162-001	.. MODULE ASSEMBLY 8" GREEN	1
3	NOT ASSIGNED	1NSG3	16440163-001	.. MODULE ASSEMBLY 12" GREEN	2
4	NOT ASSIGNED	1NSG3	16440164-001	.. MODULE ASSEMBLY 16" GREEN	1
5	NOT ASSIGNED	1NSG3	16440153-001	.. PDM BASE GREEN	1
6	NOT ASSIGNED	1NSG3	16440151	.. RATCHET STRAPS SET	2
1	8145-01-588-3672	1NSG3	15003201-002	.BOH PDM MODULE CONFIG # 01 TAN	1
2	NOT ASSIGNED	1NSG3	16440162-002	.. MODULE ASSEMBLY 8" TAN	1
3	NOT ASSIGNED	1NSG3	16440163-002	.. MODULE ASSEMBLY 12" TAN	2
4	NOT ASSIGNED	1NSG3	16440164-002	.. MODULE ASSEMBLY 16" TAN	1
5	NOT ASSIGNED	1NSG3	16440153-002	.. PDM BASE TAN	1
6	NOT ASSIGNED	1NSG3	16440151	.. RATCHET STRAPS SET	2
<b>END OF FIGURE 02</b>					

BOH PDM CONFIGURATION # 02

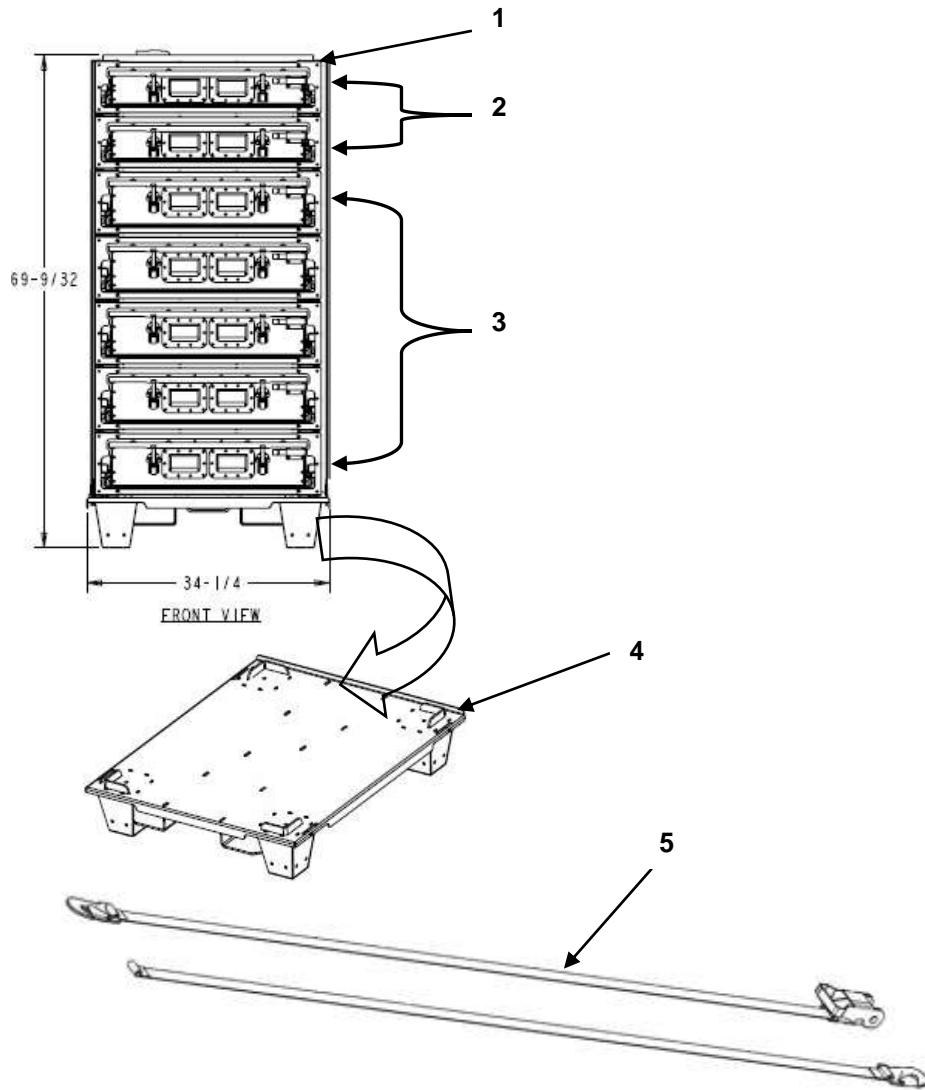

FIGURE 03 PDM CONFIGURATION # 02

(1) ITEM NO.	(2) NSN	(3) CAGEC	(4) PART NUMBER	(5) DESCRIPTION AND USABLE ON CODE (UOC)	(6) QTY
				<b>GROUP 0101 FIGURE 03 BOH PDM MODULE CONFIGURATION # 02</b>	
1	8145-01-588-3677	1NSG3	15003202-001	.BOH PDM MODULE CONFIG # 02 GREEN	1
2	NOT ASSIGNED	1NSG3	16440160-001	.. MODULE ASSEMBLY 4" GREEN	2
3	NOT ASSIGNED	1NSG3	16440161-001	.. MODULE ASSEMBLY 6" GREEN	5
4	NOT ASSIGNED	1NSG3	16440153-001	.. PDM BASE GREEN	1
5	NOT ASSIGNED	1NSG3	16440151	.. RATCHET STRAPS SET	2
1	8145-01-588-3677	1NSG3	15003202-002	.BOH PDM MODULE CONFIG # 02 TAN	1
2	NOT ASSIGNED	1NSG3	16440160-002	.. MODULE ASSEMBLY 4" TAN	2
3	NOT ASSIGNED	1NSG3	16440161-002	.. MODULE ASSEMBLY 6" TAN	5
4	NOT ASSIGNED	1NSG3	16440153-002	.. PDM BASE TAN	1
5	NOT ASSIGNED	1NSG3	16440151	.. RATCHET STRAPS SET	2
<b>END OF FIGURE 03</b>					

BOH PDM CONFIGURATION # 03

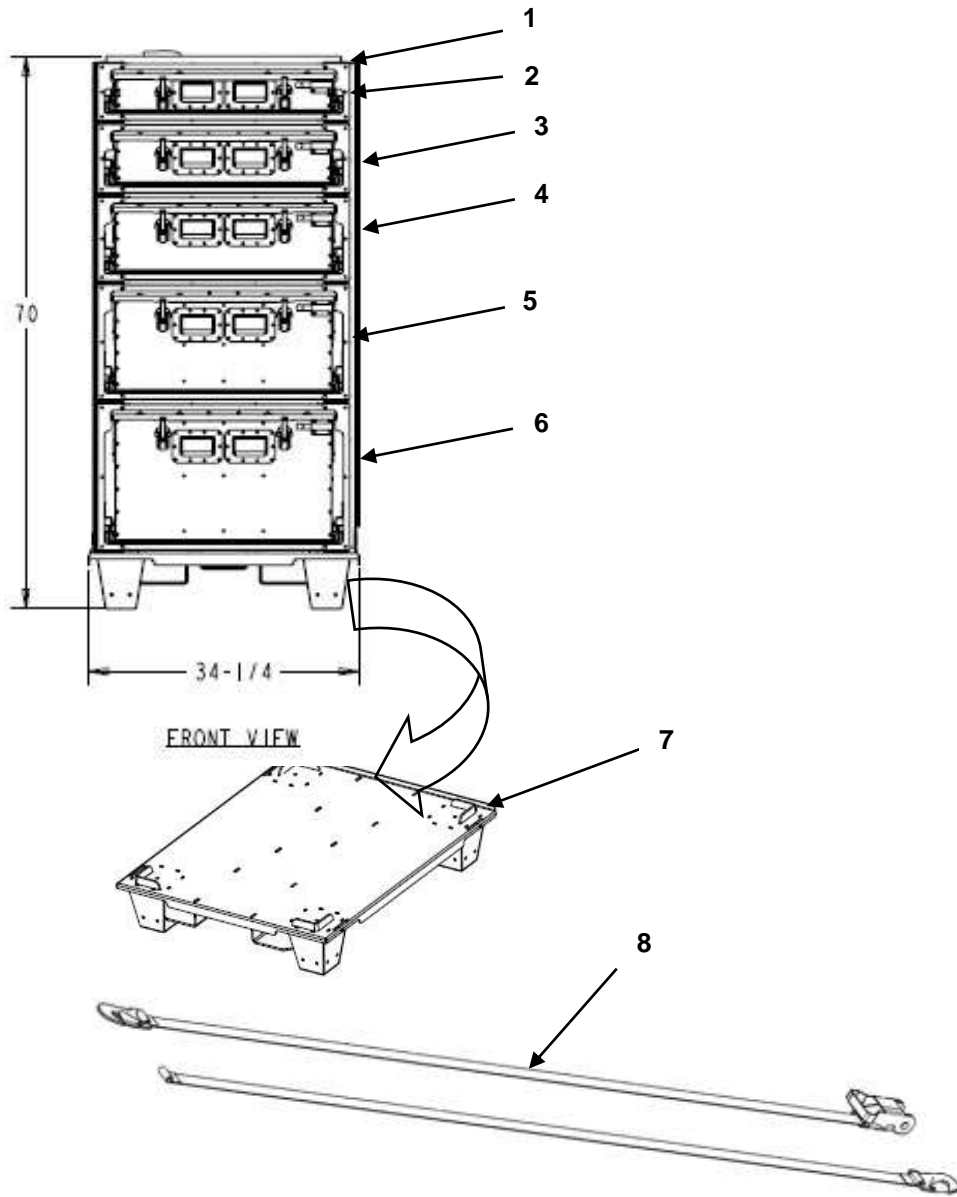

FIGURE 04 PDM CONFIGURATION # 03

(1) ITEM NO.	(2) NSN	(3) CAGEC	(4) PART NUMBER	(5) DESCRIPTION AND USABLE ON CODE (UOC)	(6) QTY
				<b>GROUP 0101 FIGURE 03 BOH PDM MODULE CONFIGURATION #03</b>	
1	8145-01-588-3678	1NSG3	15003203-001	.BOH PDM MODULE CONFIG # 03 GREEN	1
2	NOT ASSIGNED	1NSG3	16440160-001	.. MODULE ASSEMBLY 4" GREEN	1
3	NOT ASSIGNED	1NSG3	16440161-001	.. MODULE ASSEMBLY 6 " GREEN	1
4	NOT ASSIGNED	1NSG3	16440162-001	.. MODULE ASSEMBLY 8" GREEN	1
5	NOT ASSIGNED	1NSG3	16440163-001	.. MODULE ASSEMBLY 12" GREEN	1
6	NOT ASSIGNED	1NSG3	16440164-001	.. MODULE ASSEMBLY 16" GREEN	1
7	NOT ASSIGNED	1NSG3	16440153-001	.. PDM BASE GREEN	1
8	NOT ASSIGNED	1NSG3	16440151	.. RATCHET STRAPS SET	2
1	8145-01-588-3678	1NSG3	15003203-002	.BOH PDM MODULE CONFIG # 03 TAN	1
2	NOT ASSIGNED	1NSG3	16440160-002	.. MODULE ASSEMBLY 4" TAN	1
3	NOT ASSIGNED	1NSG3	16440161-002	.. MODULE ASSEMBLY 6" TAN	2
4	NOT ASSIGNED	1NSG3	16440162-002	.. MODULE ASSEMBLY 8" TAN	1
5	NOT ASSIGNED	1NSG3	16440163-002	.. MODULE ASSEMBLY 12" TAN	1
6	NOT ASSIGNED	1NSG3	16440164-002	.. MODULE ASSEMBLY 16" TAN	1
7	NOT ASSIGNED	1NSG3	16440153-002	.. PDM BASE TAN	1
8	NOT ASSIGNED	1NSG3	16440151	.. RATCHET STRAPS SET	2
<b>END OF FIGURE 04</b>					

BOH PDM CONFIGURATION # 04

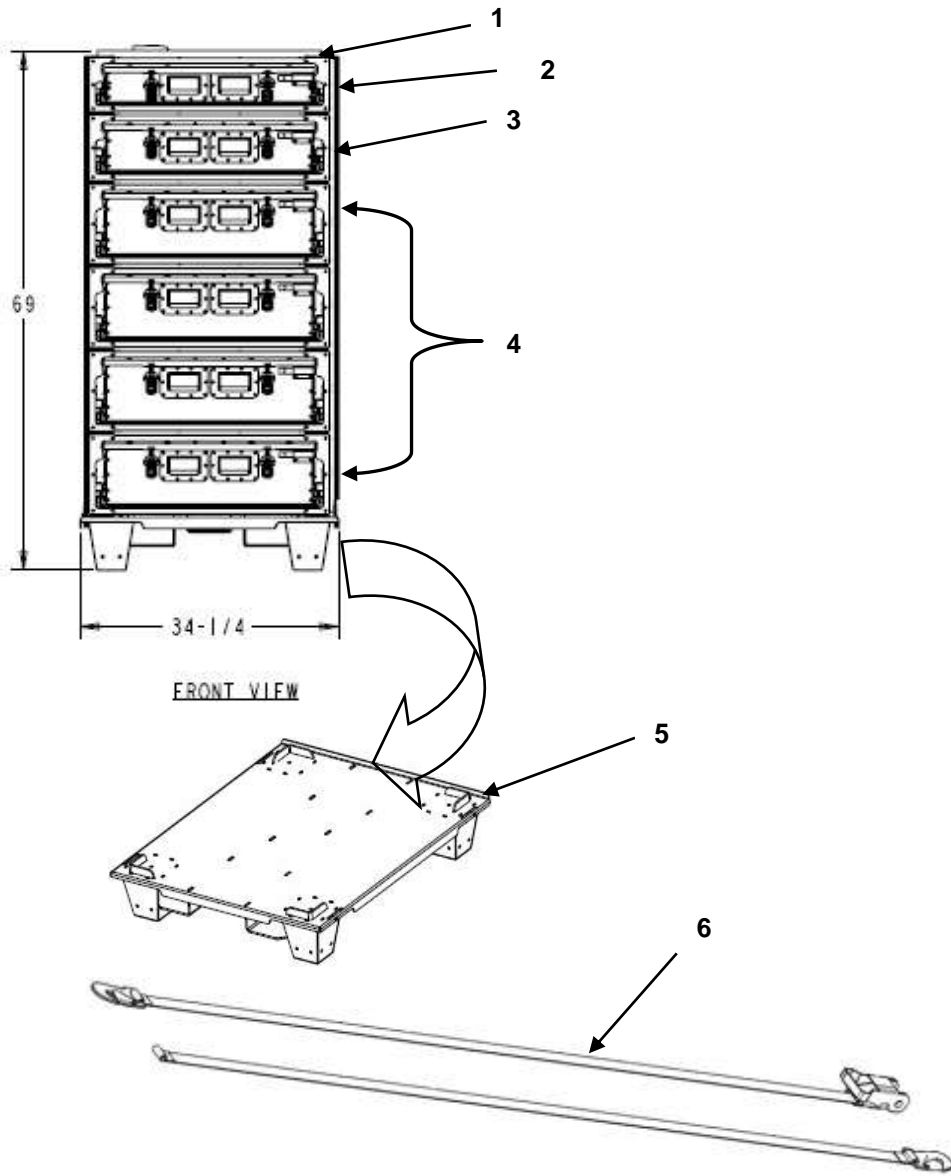

FIGURE 05 PDM CONFIGURATION # 04

(1) ITEM NO.	(2) NSN	(3) CAGEC	(4) PART NUMBER	(5) DESCRIPTION AND USABLE ON CODE (UOC)	(6) QTY
				<b>GROUP 0101 FIGURE 05 BOH PDM MODULE CONFIGURATION #04</b>	
1	8145-01-588-3688	1NSG3	15003204-001	.BOH PDM MODULE CONFIG # 04 GREEN	1
2	NOT ASSIGNED	1NSG3	16440160-001	.. MODULE ASSEMBLY 6" GREEN	1
3	NOT ASSIGNED	1NSG3	16440161-001	.. MODULE ASSEMBLY 12" GREEN	1
4	NOT ASSIGNED	1NSG3	16440162-001	.. MODULE ASSEMBLY 16" GREEN	4
5	NOT ASSIGNED	1NSG3	16440153-001	.. PDM BASE GREEN	1
6	NOT ASSIGNED	1NSG3	16440151	.. RATCHET STRAPS SET	2
1	8145-01-588-3688	1NSG3	15003204-002	.BOH PDM MODULE CONFIG # 04 TAN	1
2	NOT ASSIGNED	1NSG3	16440162-002	.. MODULE ASSEMBLY 6" TAN	1
3	NOT ASSIGNED	1NSG3	16440163-002	.. MODULE ASSEMBLY 12" TAN	1
4	NOT ASSIGNED	1NSG3	16440164-002	.. MODULE ASSEMBLY 16" TAN	4
5	NOT ASSIGNED	1NSG3	16440153-002	.. PDM BASE TAN	1
6	NOT ASSIGNED	1NSG3	16440151	.. RATCHET STRAPS SET	2
<b>END OF FIGURE 05</b>					

MODULE ASSEMBLIES 4", 6", 8", 12", 16" SIZES

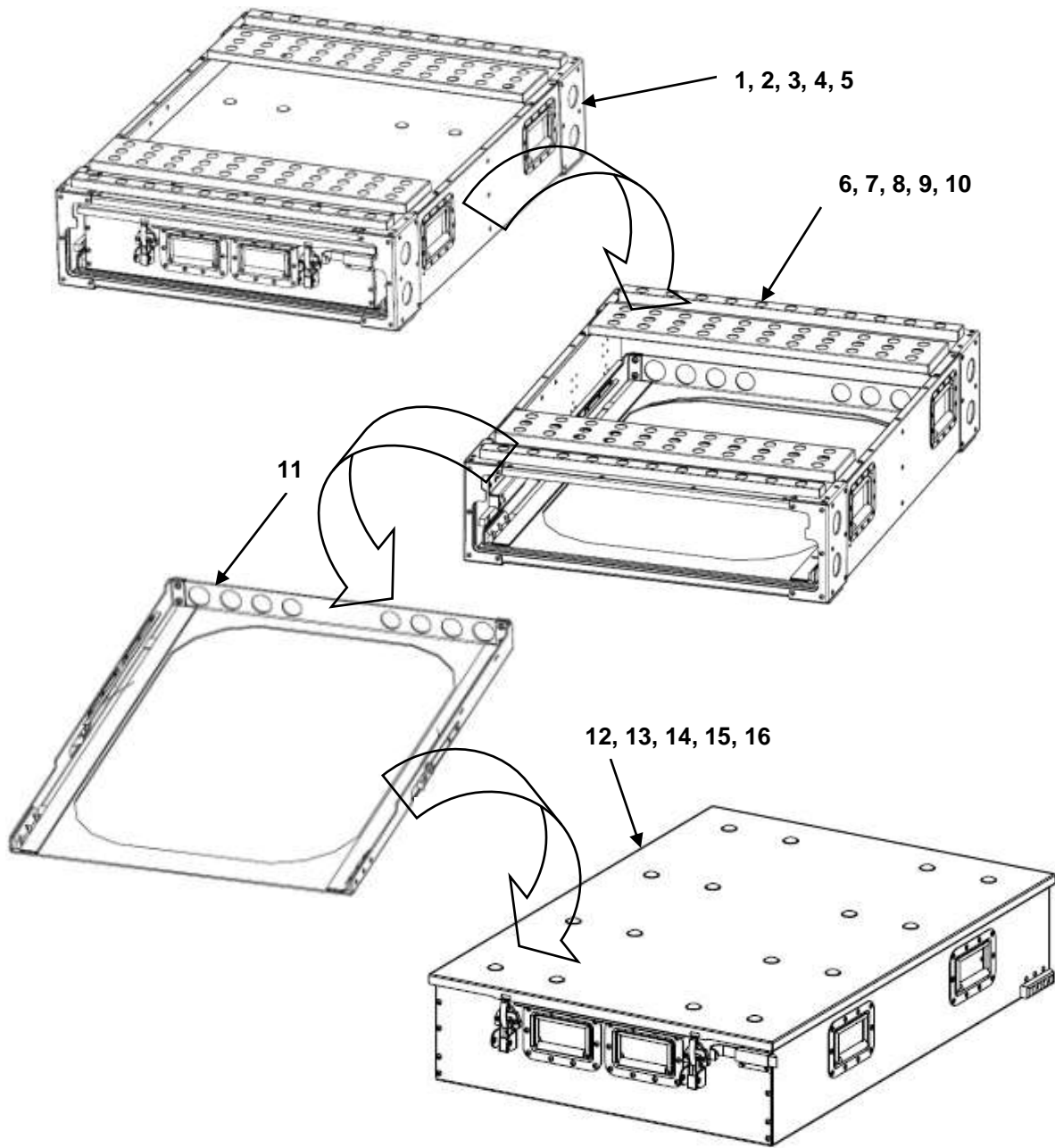

FIGURE 06 MODULE ASSEMBLIES 4", 6", 8" 12", 16" SIZES

(1) ITEM NO.	(2) NSN	(3) CAGEC	(4) PART NUMBER	(5) DESCRIPTION AND USABLE ON CODE (UOC)	(6) QTY
				<b>GROUP 0102 FIGURE 06 BOH PDM MODULE ASSEMBLIES 4", 6", 8", 12", 16" SIZES</b>	
1	NOT ASSIGNED	1NSG3	16440160-001	.PDM ASSEMBLY 4" GREEN	AR
2	NOT ASSIGNED	1NSG3	16440161-001	.PDM ASSEMBLY 6" GREEN	AR
3	NOT ASSIGNED	1NSG3	16440162-001	.PDM ASSEMBLY 8" GREEN	AR
4	NOT ASSIGNED	1NSG3	16440163-001	.PDM ASSEMBLY 12" GREEN	AR
5	NOT ASSIGNED	1NSG3	16440164-001	.PDM ASSEMBLY 16" GREEN	AR
6	NOT ASSIGNED	1NSG3	16440053-001	..PDM CASE 4" GREEN	1
7	NOT ASSIGNED	1NSG3	16440060-001	..PDM CASE 6" GREEN	1
8	NOT ASSIGNED	1NSG3	16440080-001	..PDM CASE 8" GREEN	1
9	NOT ASSIGNED	1NSG3	16440100-001	..PDM CASE 12" GREEN	1
10	NOT ASSIGNED	1NSG3	16440120-001	..PDM CASE 16" GREEN	1
11	NOT ASSIGNED	1NSG3	16440056-001	...PDM TRAY GREEN	1
12	NOT ASSIGNED	1NSG3	16440055-001	....PDM DRAWER 4" GREEN	1
13	NOT ASSIGNED	1NSG3	16440064-001	....PDM DRAWER 6" GREEN	1
14	NOT ASSIGNED	1NSG3	16440084-001	....PDM DRAWER 8" GREEN	1
15	NOT ASSIGNED	1NSG3	16440104-001	....PDM DRAWER 12" GREEN	1
16	NOT ASSIGNED	1NSG3	16440124-001	....PDM DRAWER 16" GREEN	1
1	NOT ASSIGNED	1NSG3	16440160-002	.PDM ASSEMBLY 4" TAN	AR
2	NOT ASSIGNED	1NSG3	16440161-002	.PDM ASSEMBLY 6" TAN	AR
3	NOT ASSIGNED	1NSG3	16440162-002	.PDM ASSEMBLY 8" TAN	AR
4	NOT ASSIGNED	1NSG3	16440163-002	.PDM ASSEMBLY 12" TAN	AR
5	NOT ASSIGNED	1NSG3	16440164-002	.PDM ASSEMBLY 16" TAN	AR
6	NOT ASSIGNED	1NSG3	16440053-002	..PDM CASE 4" TAN	1
7	NOT ASSIGNED	1NSG3	16440060-002	..PDM CASE 6" TAN	1
8	NOT ASSIGNED	1NSG3	16440080-002	..PDM CASE 8" TAN	1
9	NOT ASSIGNED	1NSG3	16440100-002	..PDM CASE 12" TAN	1
10	NOT ASSIGNED	1NSG3	16440120-002	..PDM CASE 16" TAN	1
11	NOT ASSIGNED	1NSG3	16440056-002	...PDM TRAY TAN	1
12	NOT ASSIGNED	1NSG3	16440055-002	....PDM DRAWER 4" TAN	1
13	NOT ASSIGNED	1NSG3	16440064-002	....PDM DRAWER 6" TAN	1
14	NOT ASSIGNED	1NSG3	16440084-002	....PDM DRAWER 8" TAN	1
15	NOT ASSIGNED	1NSG3	16440104-002	....PDM DRAWER 12" TAN	1
16	NOT ASSIGNED	1NSG3	16440124-002	....PDM DRAWER 16" TAN	1
<b>END OF FIGURE 06</b>					

PDM 4", 6", 8", 12", 16" DRAWERS

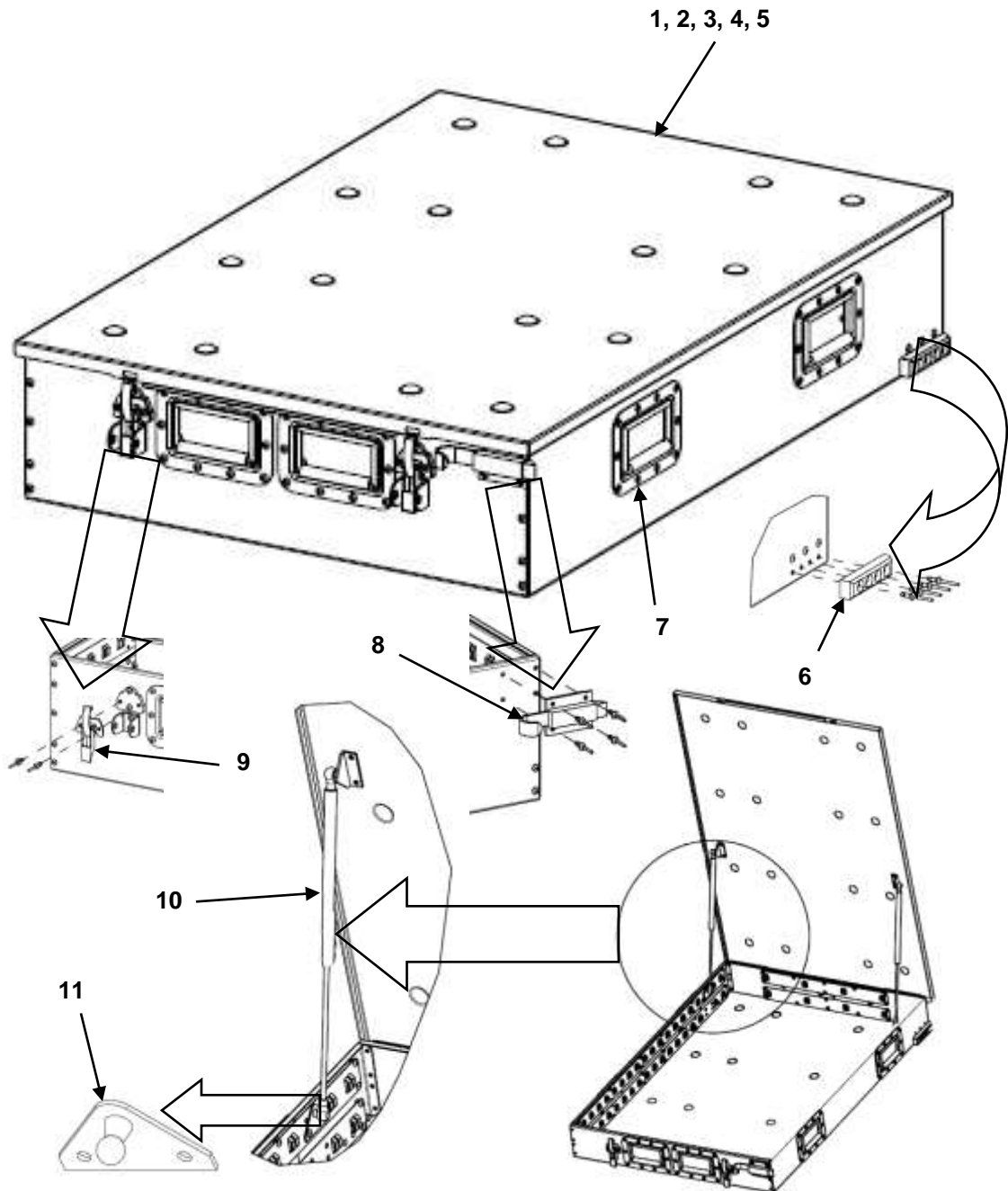

FIGURE 07 PDM 4", 6", 8", 12", 16" DRAWERS

(1) ITEM NO.	(2) NSN	(3) CAGEC	(4) PART NUMBER	(5) DESCRIPTION AND USABLE ON CODE (UOC)	(6) QTY
				<b>GROUP 0103 FIGURE 07 PDM 4", 6", 8", 12", 16" DRAWERS</b>	
1	NOT ASSIGNED	1NSG3	16440055-001	.PDM DRAWER 4" GREEN	AR
2	NOT ASSIGNED	1NSG3	16440055-001	.PDM DRAWER 6" GREEN	AR
3	NOT ASSIGNED	1NSG3	16440055-001	.PDM DRAWER 8" GREEN	AR
4	NOT ASSIGNED	1NSG3	16440055-001	.PDM DRAWER 12" GREEN	AR
5	NOT ASSIGNED	1NSG3	16440055-001	.PDM DRAWER 16" GREEN	AR
6	NOT ASSIGNED	1NSG3	15988941	..DRAWER GUIDE W/HDWR	2
7	NOT ASSIGNED	1NSG3	15988943	..DRAWER HANDLE W/ GASKET	8
8	NOT ASSIGNED	1NSG3	15988939	..DRAWER SLAM LATCH W/HDWR	1
9	NOT ASSIGNED	1NSG3	15988940	.. DRAWER LID LATCH W/HDW	2
10	NOT ASSIGNED	1NSG3	16440084	.. DRAWER GAS SPRING CYLINDER	2
11	NOT ASSIGNED	1NSG3	15988952	... GAS SPRING LOWER BRACKET W/HDWR	2
1	NOT ASSIGNED	1NSG3	16440055-002	.PDM DRAWER 4" TAN	AR
2	NOT ASSIGNED	1NSG3	16440055-002	.PDM DRAWER 6" TAN	AR
3	NOT ASSIGNED	1NSG3	16440055-002	.PDM DRAWER 8" TAN	AR
4	NOT ASSIGNED	1NSG3	16440055-002	.PDM DRAWER 12" TAN	AR
5	NOT ASSIGNED	1NSG3	16440055-002	.PDM DRAWER 16" TAN	AR
6	NOT ASSIGNED	1NSG3	15988941	..DRAWER GUIDE W/HDWR	2
7	NOT ASSIGNED	1NSG3	15988943	..DRAWER HANDLE W/ GASKET	8
8	NOT ASSIGNED	1NSG3	15988939	..DRAWER SLAM LATCH W/HDWR	1
9	NOT ASSIGNED	1NSG3	15988940	.. DRAWER LID LATCH W/HDW	2
10	NOT ASSIGNED	1NSG3	16440084	.. DRAWER GAS SPRING CYLINDER	2
11	NOT ASSIGNED	1NSG3	15988952	... GAS SPRING LOWER BRACKET W/HDWR	2
<b>END OF FIGURE 07</b>					

DRAWER LID SEALS KIT

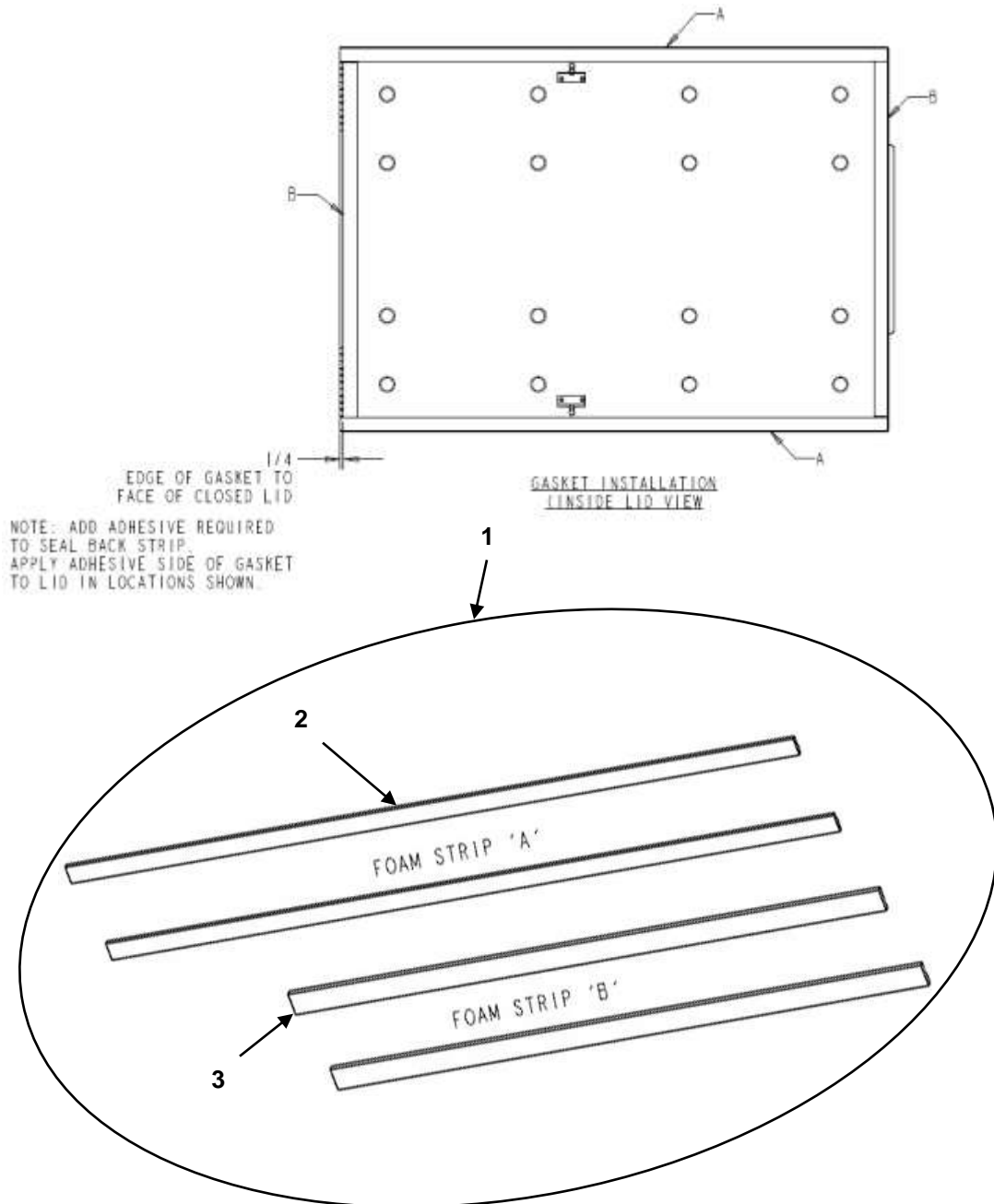

FIGURE 08 DRAWER LID SEALS KIT

---

(1) ITEM NO.	(2) NSN	(3) CAGEC	(4) PART NUMBER	(5) DESCRIPTION AND USABLE ON CODE (UOC)	(6) QTY
				<b>GROUP 0103 FIGURE 08 DRAWER LID SEALS SET</b>	
1	NOT ASSIGNED	1NSG3	15988945	.DRAWER LID SEAL KIT A & B	1
2	NOT ASSIGNED	1NSG3	16440046	..DRAWER LID SEALS SET A	1
3	NOT ASSIGNED	1NSG3	16440047	..DRAWER LID SEALS SET B	1
<b>END OF FIGURE 02</b>					

FOUR INCH DRAWER DIVIDER KITS

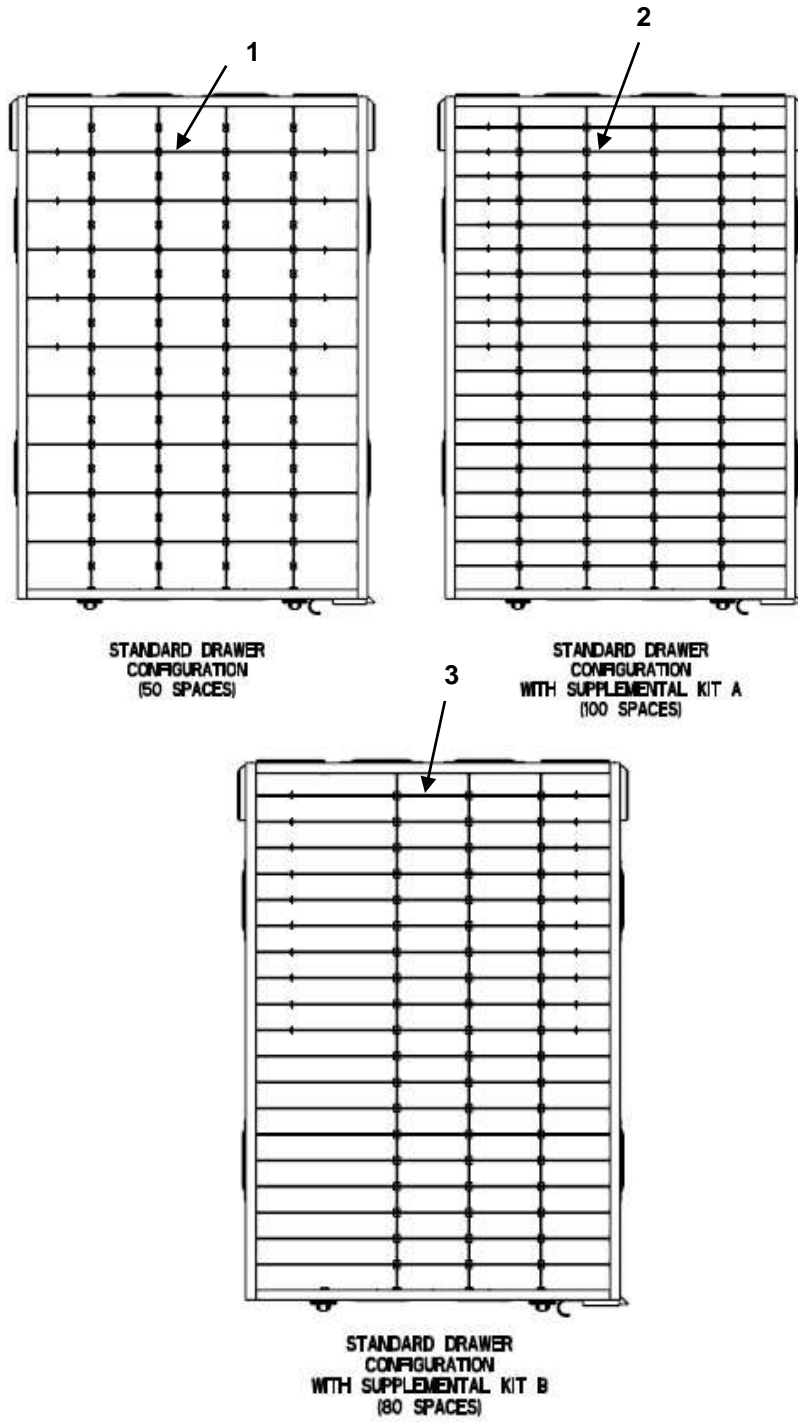

FIGURE 09 FOUR INCH DRAWER DIVIDER KITS

---

(1) ITEM NO.	(2) NSN	(3) CAGEC	(4) PART NUMBER	(5) DESCRIPTION AND USABLE ON CODE (UOC)	(6) QTY
				<b>GROUP 0103 FIGURE 09 FOUR INCH DRAWER DIVIDER KITS</b>	
1	NOT ASSIGNED	1NSG3	15988946	STANDARD 4" DIVIDER KIT	1
2	NOT ASSIGNED	1NSG3	15524009	100 SPACE SUPPLEMENTAL 4" DIVIDER KIT A	1
3	NOT ASSIGNED	1NSG3	15524010	80 SPACE SUPPLEMENTAL 4" DIVIDER KIT B	1
<b>END OF FIGURE 09</b>					

SIX INCH DRAWER DIVIDER KITS

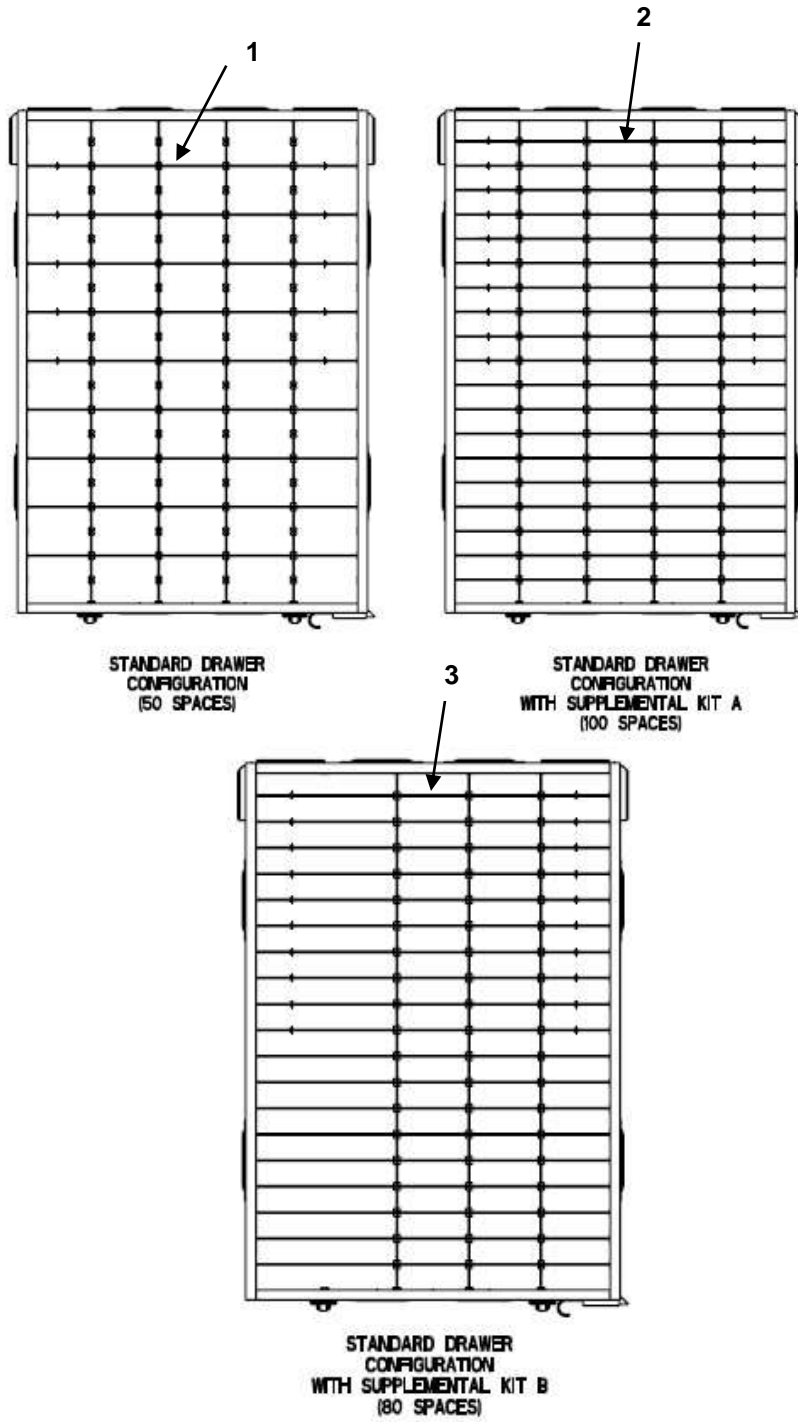

FIGURE 10 SIX INCH DRAWER DIVIDER KITS

---

(1) ITEM NO.	(2) NSN	(3) CAGEC	(4) PART NUMBER	(5) DESCRIPTION AND USABLE ON CODE (UOC)	(6) QTY
				<b>GROUP 0103 FIGURE 10 SIX INCH DRAWER DIVIDER KITS</b>	
1	NOT ASSIGNED	1NSG3	15988947	STANDARD 6" DIVIDER KIT	1
2	NOT ASSIGNED	1NSG3	15524011	100 SPACE SUPPLEMENTAL 6" DIVIDER KIT A	1
3	NOT ASSIGNED	1NSG3	15524012	80 SPACE SUPPLEMENTAL 6" DIVIDER KIT B	1
<b>END OF FIGURE 10</b>					

EIGHT INCH DRAWER DIVIDER KITS

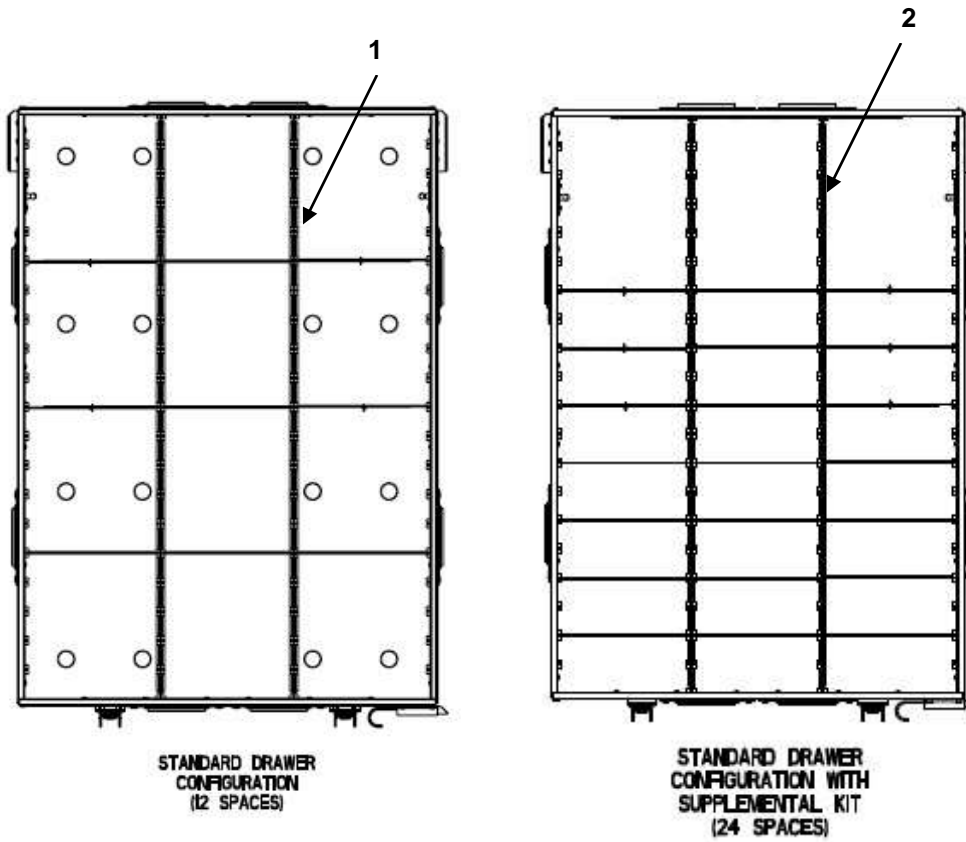

FIGURE 11 EIGHT INCH DRAWER DIVIDER KITS

---

(1) ITEM NO.	(2) NSN	(3) CAGEC	(4) PART NUMBER	(5) DESCRIPTION AND USABLE ON CODE (UOC)	(6) QTY
				<b>GROUP 0103 FIGURE 11 EIGHT INCH DRAWER DIVIDER KITS</b>	
1	NOT ASSIGNED	1NSG3	15988948	STANDARD 8" DIVIDER KIT	1
2	NOT ASSIGNED	1NSG3	15524013	24 SPACE SUPPLEMENTAL 8" DIVIDER KIT A	1
<b>END OF FIGURE 11</b>					

TWELVE INCH DRAWER DIVIDER KITS

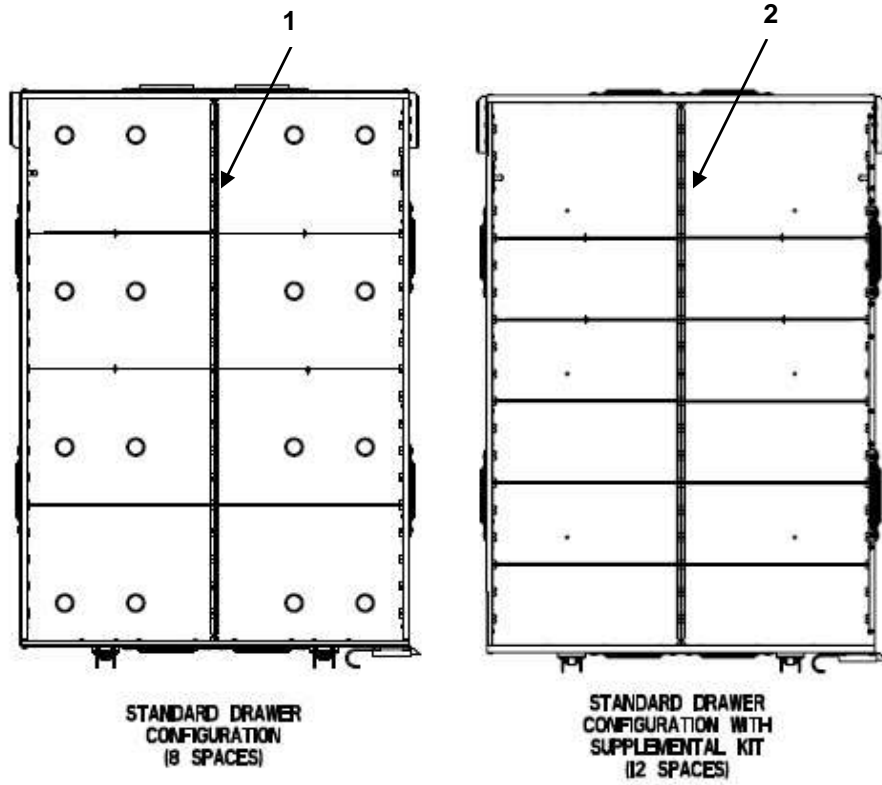

FIGURE 12 TWELVE INCH DRAWER DIVIDER KITS

---

(1) ITEM NO.	(2) NSN	(3) CAGEC	(4) PART NUMBER	(5) DESCRIPTION AND USABLE ON CODE (UOC)	(6) QTY
				<b>GROUP 0103 FIGURE 12 TWELVE INCH DRAWER DIVIDER KITS</b>	
1	NOT ASSIGNED	1NSG3	15988949	STANDARD 12" DIVIDER KIT	1
2	NOT ASSIGNED	1NSG3	15524014	12 SPACE SUPPLEMENTAL 12" DIVIDER KIT A	1
<b>END OF FIGURE 12</b>					

FIGURE 13 SIXTEEN INCH DRAWER DIVIDER KITS

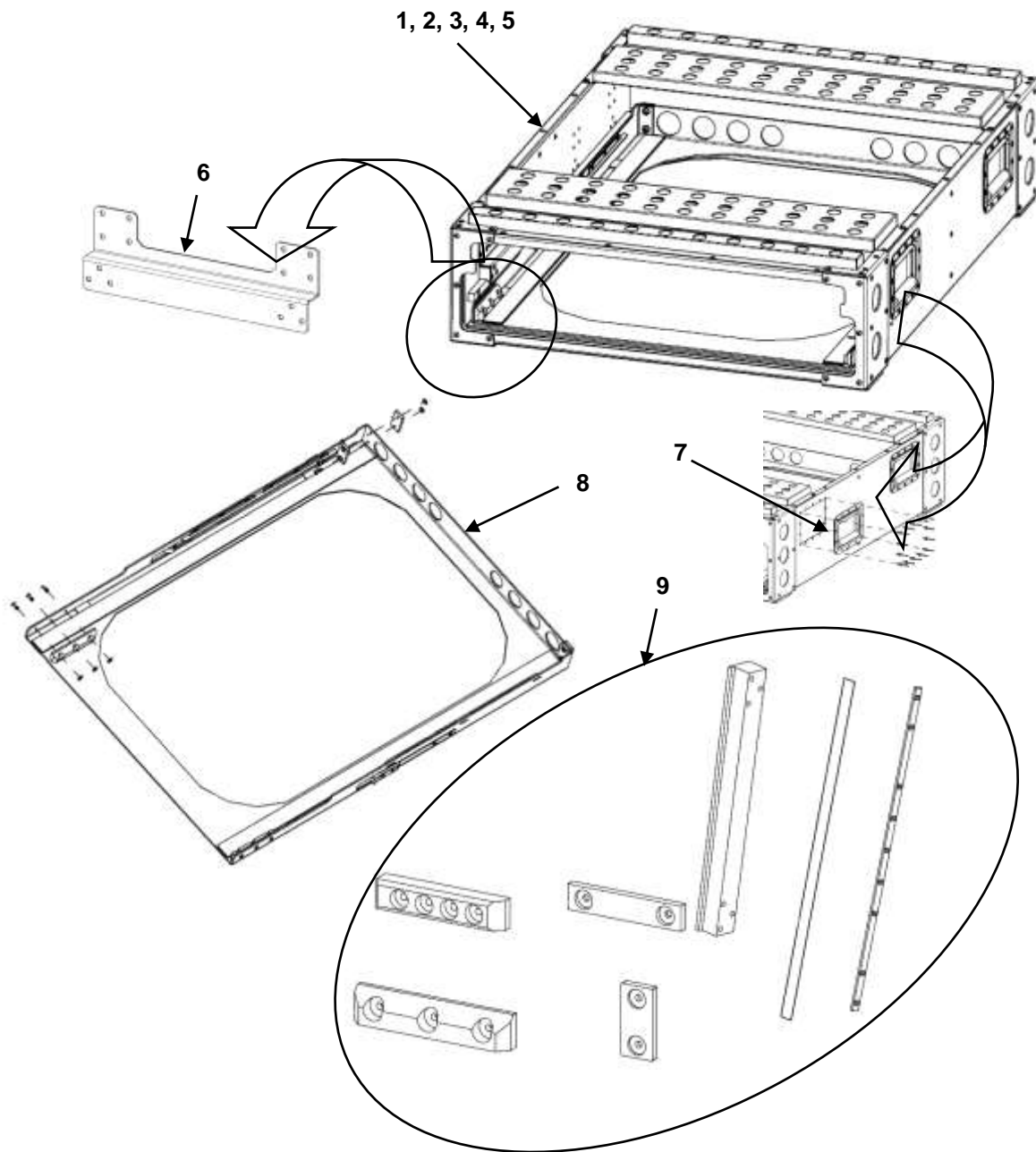

FIGURE 13 SIXTEEN INCH DRAWER DIVIDER KITS

---

(1) ITEM NO.	(2) NSN	(3) CAGEC	(4) PART NUMBER	(5) DESCRIPTION AND USABLE ON CODE (UOC)	(6) QTY
				<b>GROUP 0103 FIGURE 13 SIXTEEN INCH DRAWER DIVIDER KITS</b>	
1	NOT ASSIGNED	1NSG3	15988950	STANDARD 16" DIVIDER KIT	1
2	NOT ASSIGNED	1NSG3	15524015	12 SPACE SUPPLEMENTAL 16" DIVIDER KIT A	1
<b>END OF FIGURE 13</b>					

**PDM 4,6,8,12,16 INCH CASES  
PDM TRAY AND GUIDE STRIPS**



**FIGURE 14 PDM 4,6,8,12,16 INCH CASES  
PDM TRAY AND GUIDE STRIPS**

(1) ITEM NO.	(2) NSN	(3) CAGEC	(4) PART NUMBER	(5) DESCRIPTION AND USABLE ON CODE (UOC)	(6) QTY
				<b>GROUP 0104 FIGURE 14 PDM 4", 6", 8", 12", 16" INCH CASES AND PDM TRAY</b>	
1	NOT ASSIGNED	1NSG3	16440053-001	.PDM CASE 4" GREEN	AR
2	NOT ASSIGNED	1NSG3	16440060-001	.PDM CASE 6" GREEN	AR
3	NOT ASSIGNED	1NSG3	16440080-001	.PDM CASE 8" GREEN	AR
4	NOT ASSIGNED	1NSG3	16440100-001	.PDM CASE 12" GREEN	AR
5	NOT ASSIGNED	1NSG3	16440120-001	.PDM CASE 16" GREEN	AR
6	NOT ASSIGNED	1NSG3	15988942-001	..SLIDE GUIDE BLOCK SUPPORT W/HDWR GREEN	2
7	NOT ASSIGNED	1NSG3	15988944	..PDM CASE HANDLE W/HDWR	4
8	NOT ASSIGNED	1NSG3	16440056-001	.PDM TRAY GREEN	AR
9	NOT ASSIGNED	1NSG3	15988941	..GUIDE STRIPS KIT	1
1	NOT ASSIGNED	1NSG3	16440053-002	.PDM CASE 4" TAN	AR
2	NOT ASSIGNED	1NSG3	16440060-002	.PDM CASE 6" TAN	AR
3	NOT ASSIGNED	1NSG3	16440080-002	.PDM CASE 8" TAN	AR
4	NOT ASSIGNED	1NSG3	16440100-002	.PDM CASE 12" TAN	AR
5	NOT ASSIGNED	1NSG3	16440120-002	.PDM CASE 16" TAN	AR
6	NOT ASSIGNED	1NSG3	15988942-002	..SLIDE GUIDE BLOCK SUPPORT W/HDWR TAN	2
7	NOT ASSIGNED	1NSG3	15988944	..PDM CASE HANDLE W/HDWR	4
8	NOT ASSIGNED	1NSG3	16440056-002	.PDM TRAY TAN	AR
9	NOT ASSIGNED	1NSG3	15988941	..GUIDE STRIPS KIT	1
<b>END OF FIGURE 14</b>					

THIS PAGE WAS INTENTIONALLY LEFT BLANK



THIS PAGE WAS INTENTIONALLY LEFT BLANK

**BOH PDM PORTABLE DRAWER MODULE OPERATION MANUAL  
(INCLUDING REPAIR PARTS & SPECIAL TOOL LIST)  
FOR 4 MODELS OF PDM MODULES  
BOH FPU Field Pack/up Units**

**PART NUMBER INDEX**

PART NUMBER	FIG.	ITEM
15524009	9	2
15524010	9	3
15524011	10	2
15524012	10	3
15524013	11	2
15524014	12	2
15524015	13	2
15988939	7	8
15988940	7	9
15988941	7	6
15988941	14	9
15988943	7	7
15988943	7	7
15988944	14	7
15988945	8	1
15988946	9	1
15988947	10	1
15988948	11	1
15988949	12	1
15988950	13	1
15988952	7	11
16440046	8	2
16440047	8	3
16440084	7	10
16440151	2	6
16440151	3	5
16440151	4	8
16440151	5	6
15003201-001	1	1
15003201-001	2	1
15003201-002	1	1

PART NUMBER	FIG.	ITEM
15003201-002	2	1
15003202-001	1	2
15003202-001	3	1
15003202-002	1	2
15003202-002	3	1
15003203-001	1	3
15003203-001	4	1
15003203-002	1	3
15003203-002	4	1
15003204-001	1	4
15003204-001	5	1
15003204-002	1	4
15003204-002	5	1
15988942-001	14	6
15988942-002	14	6
16440053-001	6	6
16440053-001	14	1
16440053-002	6	6
16440053-002	14	1
16440055-001	6	12
16440055-001	7	1
16440055-001	7	2
16440055-001	7	3
16440055-001	7	4
16440055-001	7	5
16440055-002	6	12
16440055-002	7	1
16440055-002	7	2
16440055-002	7	3
16440055-002	7	4
16440055-002	7	5

PART NUMBER	FIG.	ITEM
16440056-001	6	11
16440056-001	14	8
16440056-002	6	11
16440056-002	14	8
16440060-001	6	7
16440060-001	14	2
16440060-002	6	7
16440060-002	14	2
16440064-001	6	13
16440064-002	6	13
16440080-001	6	8
16440080-001	14	3
16440080-002	6	8
16440080-002	14	3
16440084-001	6	14
16440084-002	6	14
16440100-001	6	9
16440100-001	14	4
16440100-002	6	9
16440100-002	14	4
16440104-001	6	15
16440104-002	6	15
16440120-001	6	10
16440120-001	14	5
16440120-002	6	10
16440120-002	14	5
16440124-001	6	16
16440124-002	6	16
16440153-001	2	5
16440153-001	3	4
16440153-001	4	7
16440153-001	5	5
16440153-002	2	5
16440153-002	3	4
16440153-002	4	7
16440153-002	5	5
16440160-001	3	2
16440160-001	4	2

PART NUMBER	FIG.	ITEM
16440160-001	5	2
16440160-001	6	1
16440160-002	3	2
16440160-002	4	2
16440160-002	6	1
16440161-001	3	3
16440161-001	4	3
16440161-001	5	3
16440161-001	6	2
16440161-002	3	3
16440161-002	4	3
16440161-002	6	2
16440162-001	2	2
16440162-001	4	4
16440162-001	5	4
16440162-001	6	3
16440162-002	2	2
16440162-002	4	4
16440162-002	5	2
16440162-002	6	3
16440163-001	2	3
16440163-001	4	5
16440163-002	2	3
16440163-002	4	5
16440163-002	5	3
16440163-002	6	4
16440164-001	2	4
16440164-001	4	6
16440164-001	6	5
16440164-002	2	4
16440164-002	4	6
16440164-002	5	4
16440164-002	6	5
<b>END OF PART NUMBER TABLES</b>		

**Boh Environmental, LLC**

**MANUFACTURER'S LIMITED WARRANTY TERMS**

Boh Environmental, LLC (BOH) warrants that the Products, including the Field Pack-Up (FPU Systems) and other Containerized Mission Systems, it manufactures shall be free from defects in materials and workmanship for a period of one year from date of purchase when normally used and operated by the Customer. Unused Product containing missing or defective components shall be returned within the warranty period, with proof of purchase, to BOH with transportation charges prepaid. BOH, at its option, shall supply a replacement item(s) or refund the purchase price of the Product. BOH will determine, at its sole discretion, that the claim is a valid warranty item. If so, BOH will pay costs (actual transportation plus handling charge) for shipping of the replacement item, when this option is selected.

This warranty is void if Products have been damaged by the Customer as the result of improper or unreasonable use, or other causes not arising out of defects in material or workmanship. The warranty is also void if the Product has at any time been stored or used other than in accordance with the directions set out in the literature relating to the Product. BOH makes no other warranty or representation concerning the Products except that each will meet the performance specifications set forth in the literature relating to the Product. There are no further warranties, including any warranty of merchantability or fitness for a particular purpose covering the Product.

BOH will, at its option, either (1) credit user in the amount paid for any Product which does not perform to these specifications, or (2) replace such Product, provided user so notifies BOH within twelve (12) months of the Products purchase date. BOH shall not be responsible for any consequential damages to user arising as a result of such performance. The Customer will return the item at their cost, if required. BOH may elect to have its representative inspect the item to validate the claim.

Other product components included in the fabrication of items purchased under contract (e.g. air conditioners and generators) that are not manufactured by Boh Environmental are warranted by their individual manufacturer. Copies of such warranties are supplied with the finished Product or are available through Boh Environmental.

THIS PAGE WAS INTENTIONALLY LEFT BLANK

## THE METRIC SYSTEM AND EQUIVALENTS

### Linear Measure

1 centimeter = 10 millimeters = .39 inch

1 decimeter = 10 centimeters = 3.94 inches

1 meter = 10 decimeters = 39.37 inches

1 decameter = 10 meters = 32.8 feet

1 hectometer = 10 decameters = 328.08 feet

1 kilometer = 10 hectometers = 3,280.8 feet

### Weights

1 centigram = 10 milligrams = .15 grain

1 decigram = 10 centigrams = 1.54 grains

1 gram = 10 decigrams = .035 ounce

1 dekagram = 10 grams = .35 ounce

1 hectogram = 10 dekagrams = 3.52 ounces

1 kilogram = 10 hectograms = 2.2 pounds

1 quintal = 100 kilograms = 220.46 pounds

1 metric ton = 10 quintals = 1.1 short tons

### Liquid Measure

1 centiliter = 10 milliliters = .34 fl. ounce

1 deciliter = 10 centiliters = 3.38 fl. ounces

1 liter = 10 deciliters = 33.81 fl. ounces

1 deciliter = 10 liters = 2.64 gallons

1 hectoliter = 10 deciliters = 26.42 gallons

1 kiloliter = 10 hectoliters = 264.18 gallons

### Square Measure

1 sq. centimeter = 100 sq. millimeters = .155 sq. inch

1 sq. decimeter = 100 sq. centimeters = 15.5 sq. inches

1 sq. meter (centare) = 100 sq. decimeters = 10.76 sq. feet

1 sq. decameter (are) = 100 sq. meters = 1,076.4 sq. feet

1 sq. hectometer (hectare) = 100 sq. decameters = 2.47 acres

1 sq. kilometer = 100 sq. hectometers = .386 sq. mile

### Cubic Measure

1 cu. centimeter = 1000 cu. millimeters = .06 cu. inch

1 cu. decimeter = 1000 cu. centimeters = 61.02 cu. inches

1 cu. meter = 1000 cu. decimeters = 35.31 feet

## Approximate Conversion Factors

To change	To	Multiply by	To change	To	Multiply by
Inches	centimeters	2.540	ounce-inches	Newton-meters	0.007062
feet	meters	0.305	centimeters	inches	0.394
yards	meters	0.914	meters	feet	3.280
miles	kilometers	1.609	meters	yards	1.094
square inches	square centimeters	6.451	kilometers	miles	0.621
square feet	square meters	0.093	square centimeters	square inches	0.155
square yards	square meters	0.836	square meters	square feet	10.764
square miles	square kilometers	2.590	square meters	square yards	1.196
acres	square hectometers	0.405	square kilometers	square miles	0.386
cubic feet	cubic meters	0.028	square hectometers	acres	2.471
cubic yards	cubic meters	0.765	cubic meters	cubic feet	35.315
fluid ounces	milliliters	29.573	cubic meters	cubic yards	1.308
pints	liters	0.473	milliliters	fluid ounces	0.034
quarts	liters	0.946	liters	pints	2.113
gallons	liters	3.785	liters	quarts	1.057
ounces	grams	28.349	liters	gallons	0.264
pounds	kilograms	0.454	grams	ounces	0.035
short tons	metric tons	0.907	kilograms	pounds	2.205
pound-feet	Newton-meters	1.356	metric tons	short tons	1.102
pound-inches	Newton -meters	0.11296			

## Temperature (Exact)

$$_F = \frac{5}{9} (C - 32) + 32$$
 Fahrenheit temperature

$$_C = \frac{5}{9} (F - 32)$$
 Celsius temperature