

CHAPTER 5
CONTAINER MAINTENANCE INSTRUCTIONS

This page was intentionally left blank

**FPU SYSTEMS OPERATION MANUAL
(INCLUDING REPAIR PARTS & ACCESSORIES)
FOR
FPU/BOH CARGO CONTAINERS
MODELS FPU-8-2, BOH-CARGO-12-1, BOH-CARGO-6 & FPU-20-1 & FPU-20-2
MAINTENANCE INSTRUCTIONS**

DOOR ASSEMBLY BOH-CARGO-12 and BOH-6

INSPECT, SERVICE, ADJUST

INITIAL SETUP:

Material/Parts

Lubricant (see Table 2 Lubrication in WP 0015)

Personnel Required

Two

Tools

Rags, General Mechanic's Tool Kit, Ladder

References

WP 0015 00

Equipment Condition

Door Adjust and Repair

Inspect

With doors open, inspect seal surfaces, and report problems with door seal to direct support maintenance.

SERVICE

1. Wipe seal surfaces clean and apply a light coat of lubrication (refer to Table 2 Lubrication in WP 0015) to seal mating surfaces.
2. Report gouges, cracks, rips, tears, etc. in door seal to direct support maintenance.

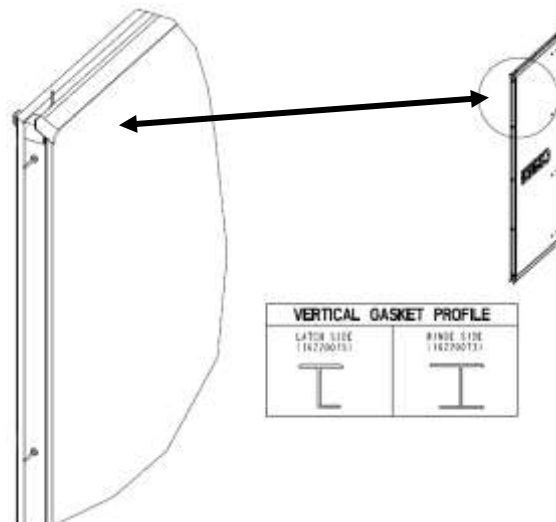

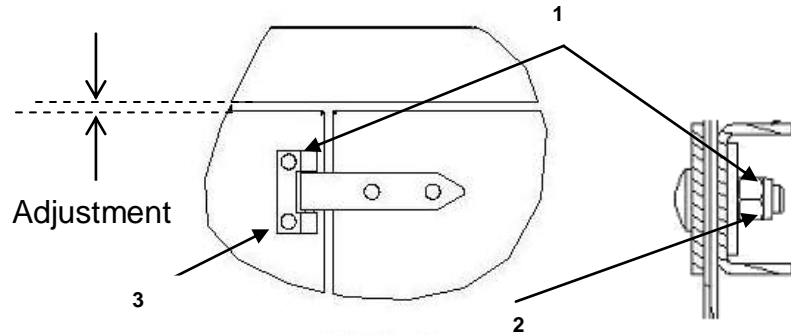
ALIGN**Align barn type doors BOH-CARGO-12-1 and BOH-6****NOTE**

When aligning the BOH-CARGO-12-1 bi-fold doors, align the door attached to the upright beam first.

1. Ensure the doors close smoothly without obstruction the container is on a level surface.
2. Align as needed, remove drawers/pallets directly behind the door to be aligned.
3. With door in the open position loosen hinge nuts (2) on the door hinge base (2). Do not loosen the nuts on the hinge tang (1).
4. Close the misaligned door leaving the opposite door open to allow access for measurements.
5. Using a pry bar, center door with equal distance from top of door edge to header and bottom door edge to threshold.
6. A narrow wood wedge may be used to retain the adjusted gap height at the bottom.

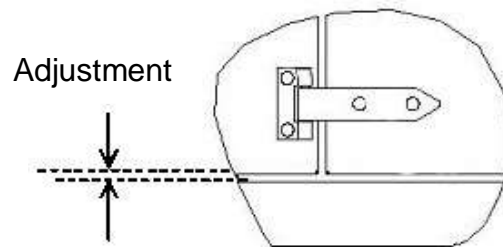

7. Retighten bolts on the door hinges.
8. Reopen the door to be aligned.
9. Loosen the hinge base nuts on the door that is being aligned. Do not loosen the hinge tang (1).
10. Close the misaligned and opposite doors.

11. Check the gap at the top and bottom, retighten hinge nuts base (2) on the adjusted door.

REPLACE

Replacement of Door Hinge

1. Remove hinge bolts (1), locknuts, brackets, tabs and hinge (2) to be replaced.

NOTE

Only replace one hinge at a time to avoid alignment problems.

2. Install bolts (1), and replacement hinge (2).
3. Check door operation, alignment and align as required.

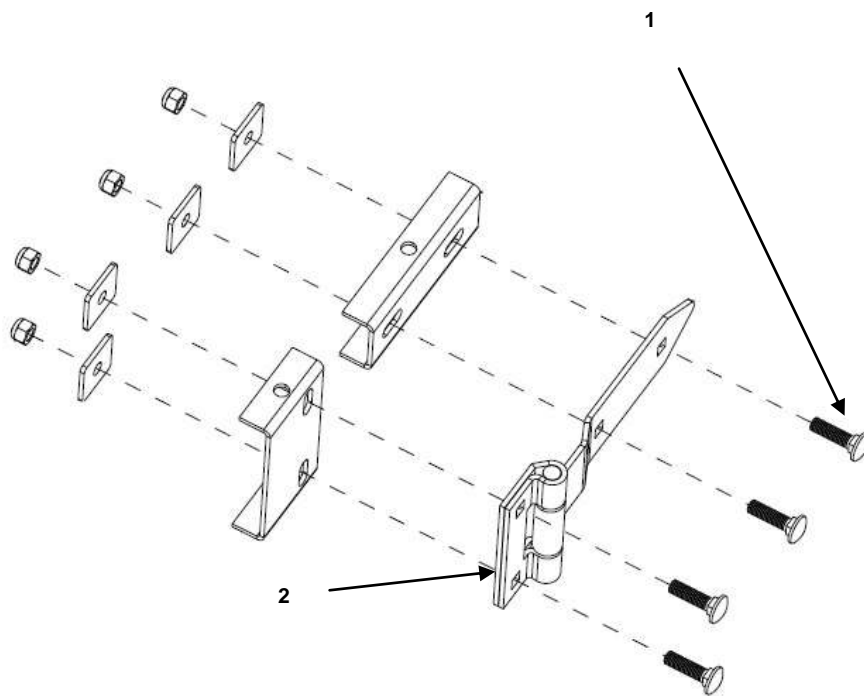

REPLACE

Replacement of BOH-CARGO-12-1 and BOH-CARGO-6 Barn Type Door Seals

1. Obtain the proper door seal replacement kit.
2. The seals are retained by 3/16" pop rivets (1) in the center of the seal.
3. Drill the core with a 1/8" drill bit and remove the pop rivets (1).
4. Remove the seal segment (2) and corner angle piece (3) and tabs (4).
5. Clean the surface prior to installing the seals
6. Apply sealant (5) to the parameter of the door edge and mating edge of the seal.
7. Install new seal segment, align holes with a #11 drill or bit insert 3/16" pop rivets.
8. Seat the seal and fasten the rivets with pop rivet tool.
9. Apply adhesive (6) to the corner tabs (4) and angle pieces (3).
10. Permit drying time for the adhesive (6).

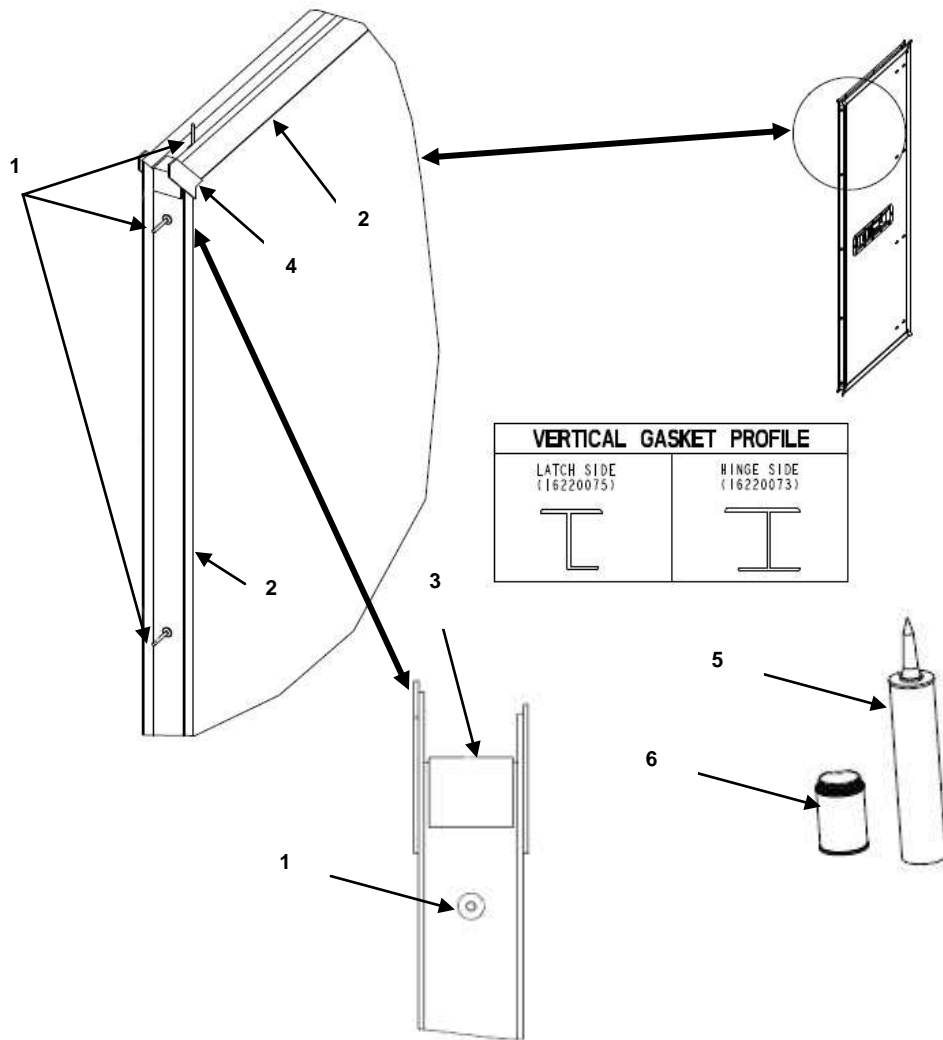

END OF WORK PACKAGE

**FPU SYSTEMS OPERATION MANUAL
(INCLUDING REPAIR PARTS & ACCESSORIES)
FOR
FPU/BOH CARGO CONTAINERS
MODELS FPU-8-2, BOH-CARGO-12-1, BOH-CARGO-6 & FPU-20-1 & FPU-20-2
MAINTENANCE INSTRUCTIONS**

POCKET DOOR REPAIR FPU-20- 1&2, FPU-8-2

INITIAL SETUP:

Materiel/Parts

Personnel Required

Two

Large Screw Driver, 9/16" and 1/2 "Open End Wrenches, Step Ladder

References

Equipment Condition

Door Adjust and Replace

FPU-8-2

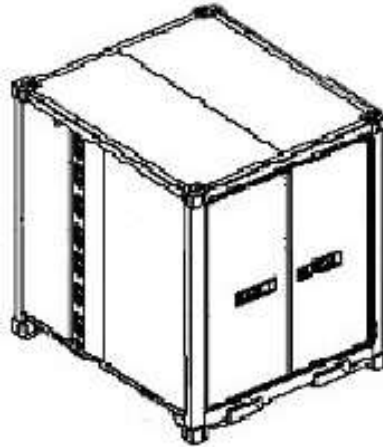

FPU-20-1 & 2

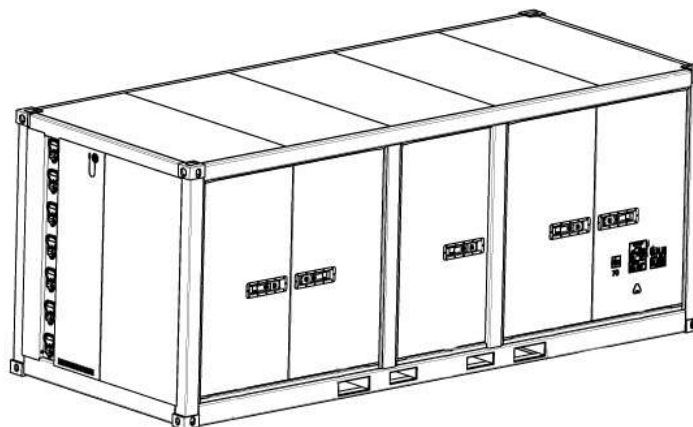

POCKET DOOR INSTALLATION

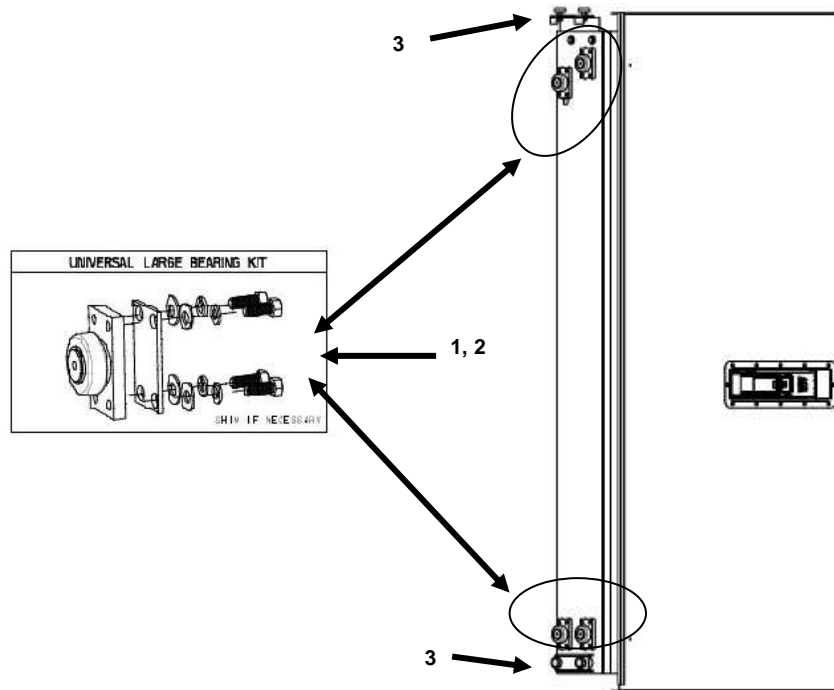

NOTE

Do not install the small bearings (3) top and bottom at this time.

1. Place the door on a firm supporting table, palette or saw horses.
2. Attach the four large bearings (1), to the door leave the hardware (2) loose for installation.

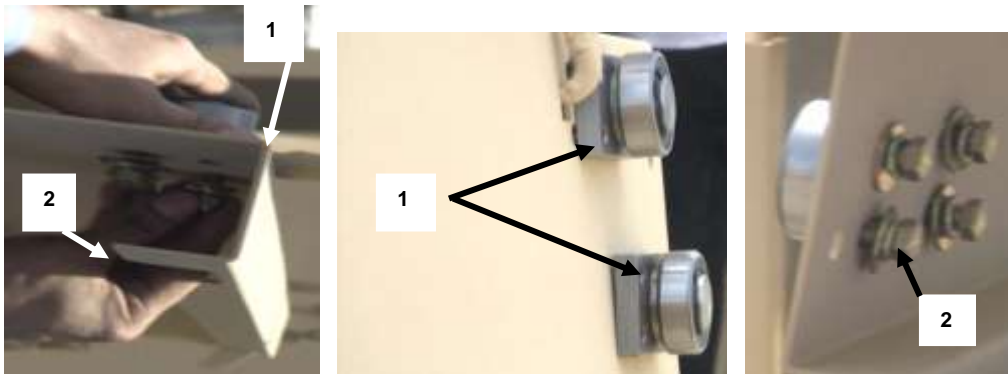

WARNING



Seek assistance when lifting or installing a pocket door.

3. With an assistant supporting the door the full open position lift and guide the door support assembly and bearings (1) into the top and bottom tracks (2) place the upper top bearing in the track and the lower top bearing (4) under the track (2) guide both bottom bearings (5) into the bottom track (2).

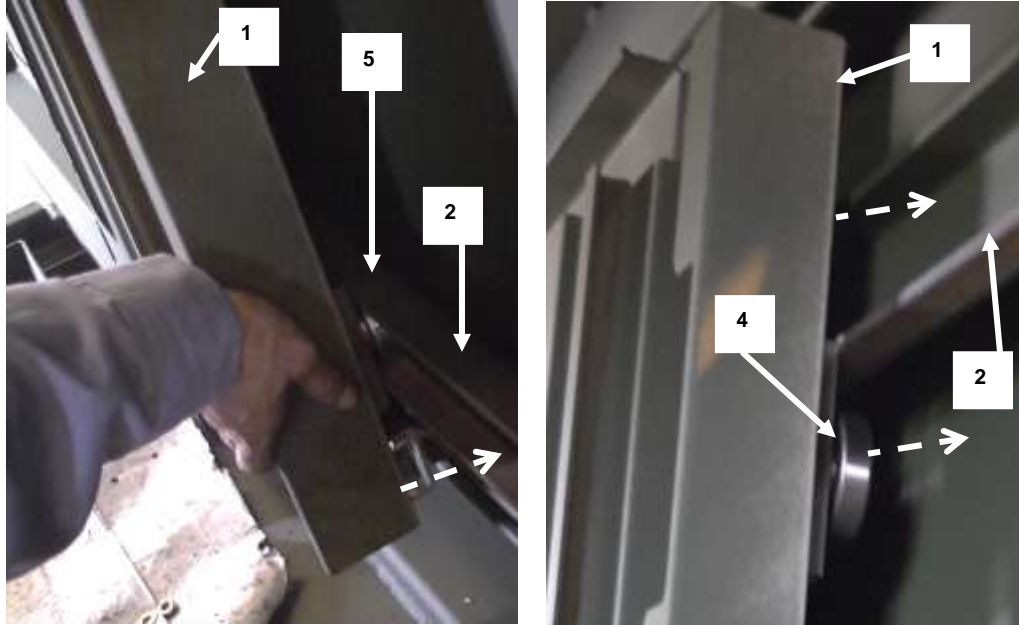

NOTE

The lower top bearing (4) will be drawn up to contact the track when adjustment is made.

3. Install the two top small bearings (6) via the entry cutout (7) in the top ceiling track.
4. Install the mounting plate (9) to the bearings (6) tighten just the bearings.
5. Install the plate (9) to the door support (10) with the plate hardware (8) finger tight.

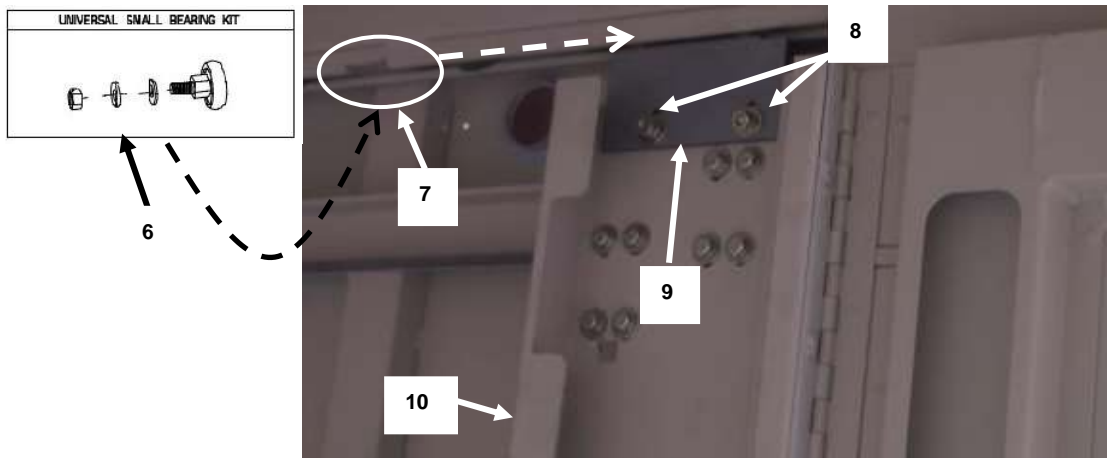

NOTE

The door should now be supported by the bearings.

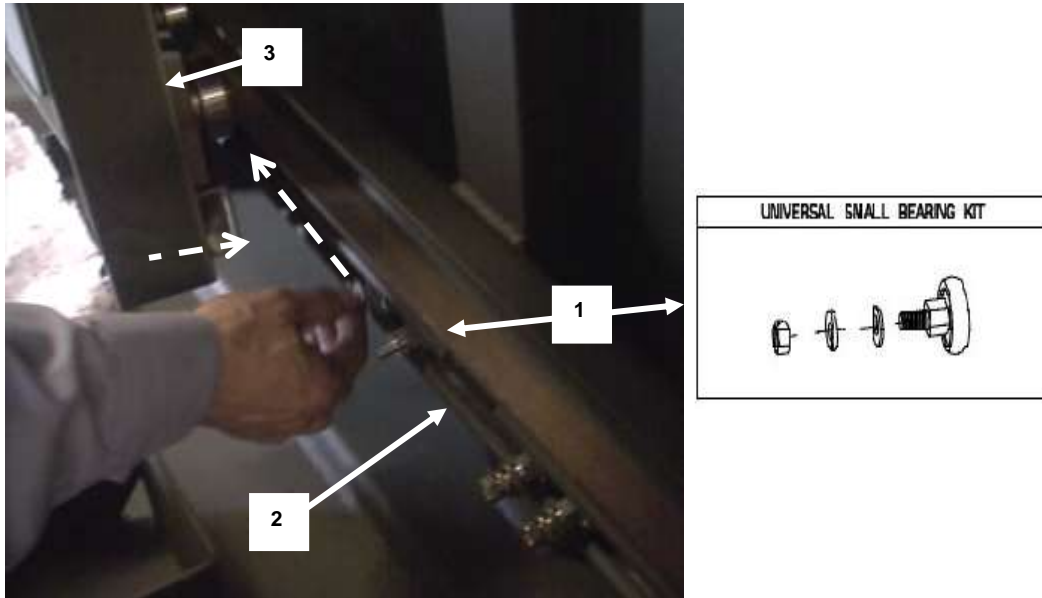

6. To install two the Small bearings (1) in the small lower track (2), remove the nuts and washers and position them behind the door support (3) with the bearing bolts through the door support (3).
7. Place the small bearing flat washers, lock washers and nuts (4) on the small bearing bolts, finger tight.

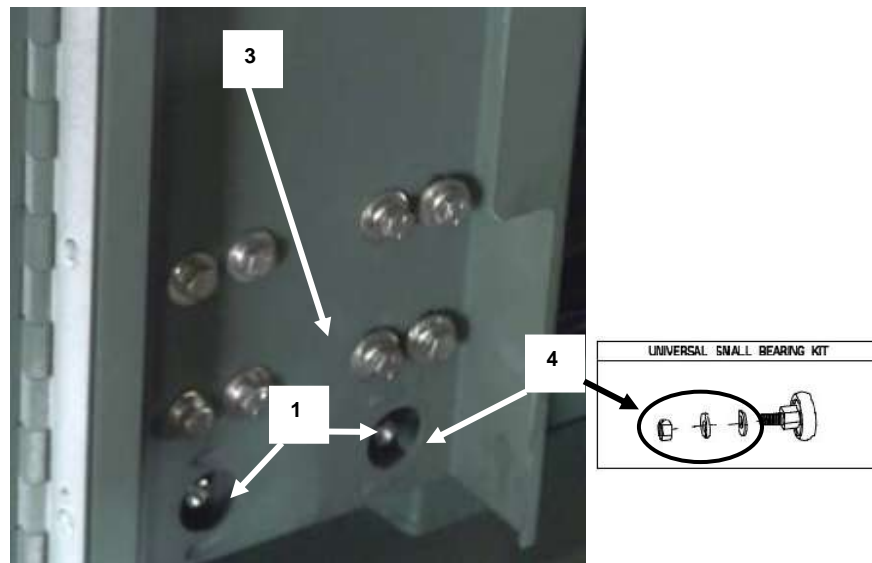

ADJUST TOP BEARINGS

1. Align the door support (1) plumb with the wall structural uprights.
2. Obtain some 2 x 4 scraps of wood for a wedge (2) and fulcrum block (3) to adjust the door and bearing positions.
3. Place the wedge (2) and fulcrum block (3) in the position as shown and apply downward pressure to set the door in position and tighten the top four large bearing bolts (4) using a 9/16" wrench.

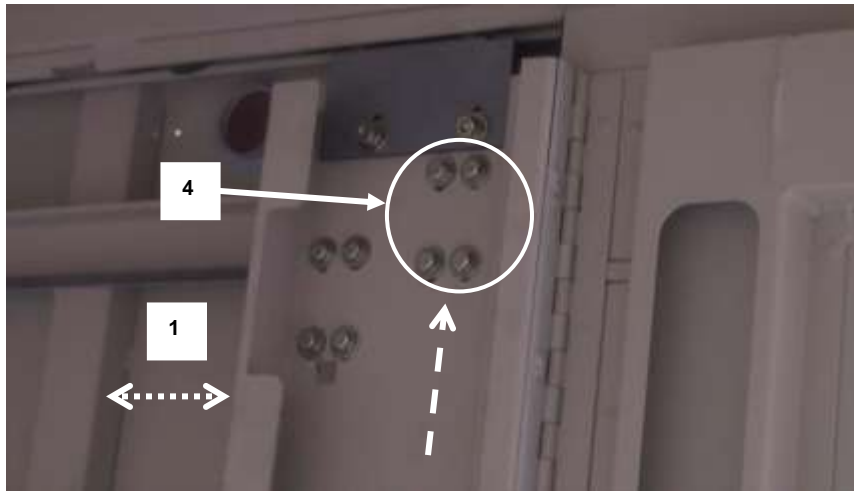

4. Release tension on the wedge and remove the wedge (2) and fulcrum block (3).

5. Obtain a large screw driver (1) or pry bar to adjust the position of the lower top bearing.

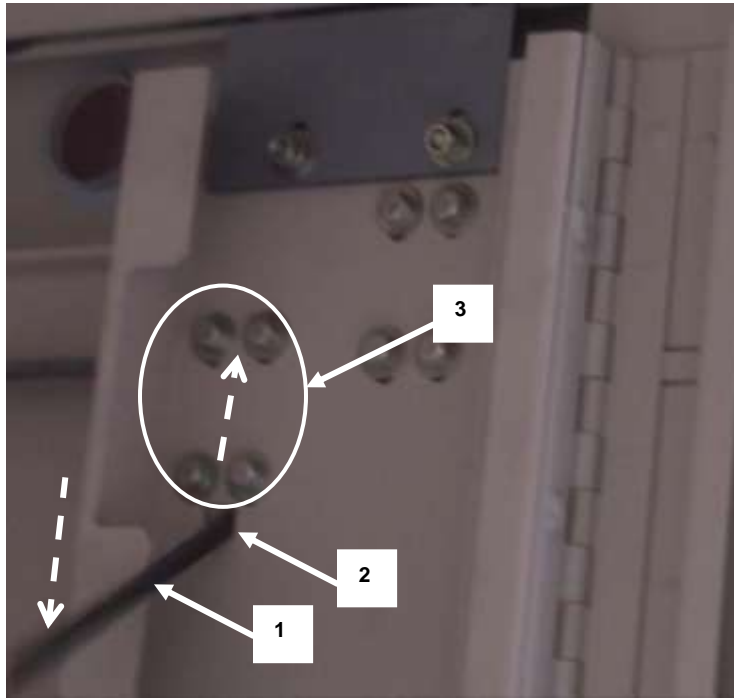

6. Insert the screw driver (1) into the access hole (2) and pull downward contacting the bearing plate.
7. With the screw driver force the bearing up against the bottom of the track and tighten the four large bearing bolts (3) using a 9/16" wrench.
8. Push the small bearing plate (4) up and tighten the two nuts and bolts (5) using a 9/16" wrench.

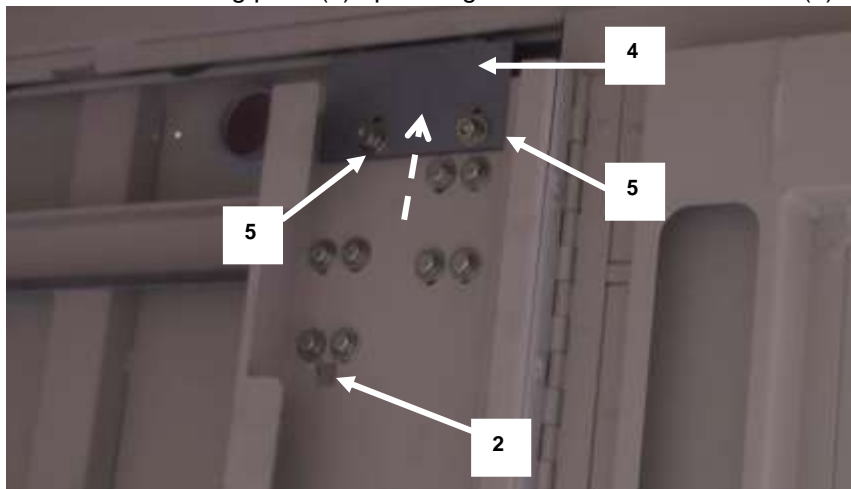

ADJUST BOTTOM BEARINGS

1. Return to the bottom of the door support and adjust the bottom bearings.
2. Reach behind the door support and push the bearing block downward to contact the bottom of the track and using a 9/16" wrench tighten the four bearing bolts (1) next to the door hinge (2).

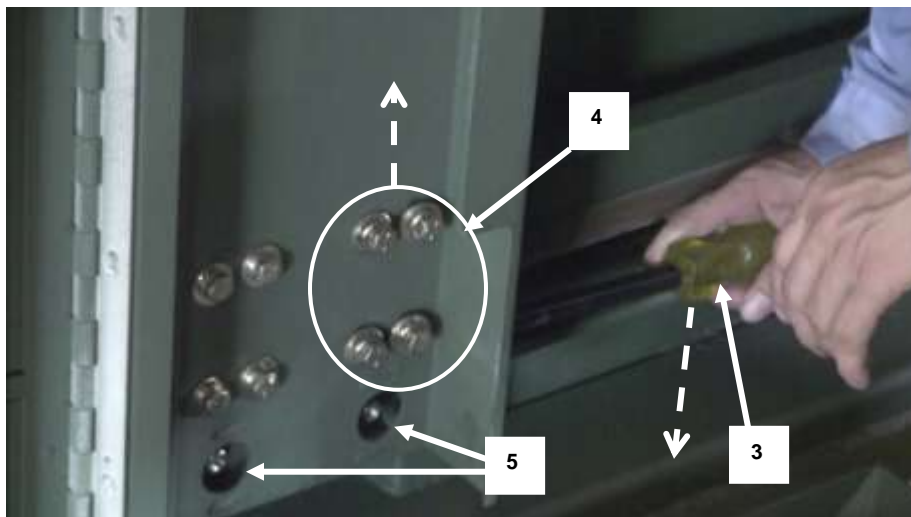
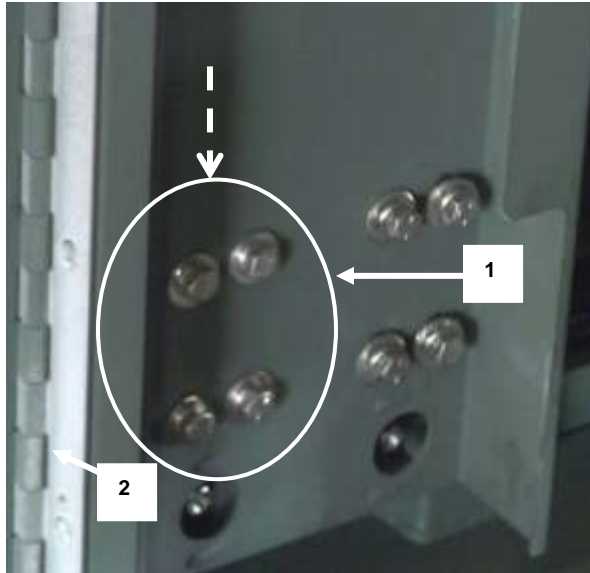

3. Pry the bearing up to meet the top edge of track, by pushing down on the screw driver (3) and tighten the four large bearing bolts (4) using a 9/16" wrench.
4. Tighten the two small bearing nuts (5) using a 1/2" wrench.

CHECK ALIGNMENT

1. Pull out and slide the door to the closed position.
2. Obtain a ladder and visually check for even clearance top edge and bottom of the door.
3. Open the door and push the door to the storage position and check for freedom of movement.
4. Readjust the bearings if necessary.

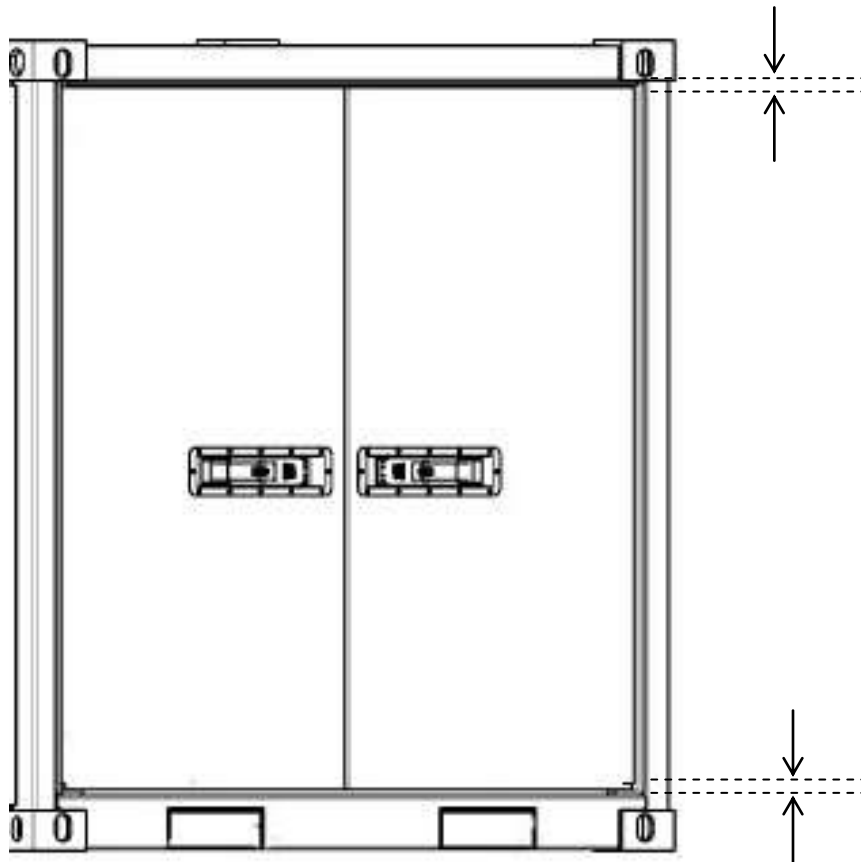
**END OF WORK PACKAGE**

**FPU SYSTEMS OPERATION MANUAL
(INCLUDING REPAIR PARTS & ACCESSORIES)
FOR
FPU/BOH CARGO CONTAINERS
MODELS FPU-8-2, BOH-CARGO-12-1, BOH-CARGO-6 & FPU-20-1 & FPU-20-2
MAINTENANCE INSTRUCTIONS**

POCKET DOOR REPAIR FPU-20- 1&2, FPU-8-2

INITIAL SETUP:

Materiel/Parts

Seal Kit

Personnel Required

Two

Putty knife, Robber Mallet, Scissors, Step Ladder, Rags, Mineral Spirits

References

Equipment Condition

Pocket door seal installation

FPU FRAME SEAL INSTALLATION

NOTE

Pocket door seal installation kits come with adhesive, sealant and peel and stick lengths of seal. Some segments will require additional adhesive (turbo fuse glue) (1) to be applied that insures additional bonding and sealant to insure water tight protection at the lower corners (2) of the containers.



NOTE

Some segments require trimming and joined to the fit frame contours.



CAUTION

All seal surfaces must be clean, free of dust, dirt, grease, oil and moisture before applying the seals.
Wipe with clean rags and mineral spirits prior to installing the seals.

1. Remove the old seal material with a putty knife or scraping tool.
2. Ensure that the surfaces are clean and free of dirt oil or grease clean rags and mineral spirits.
3. Dry fit by placing the seal with the backing paper still attached in the desired position.
4. Establish the approximate length and position of the seal.

NOTE

Do not cut the seal or peel back the paper backing (1) at this time.
Seals should not be stretched, but positioned in a relaxed state.

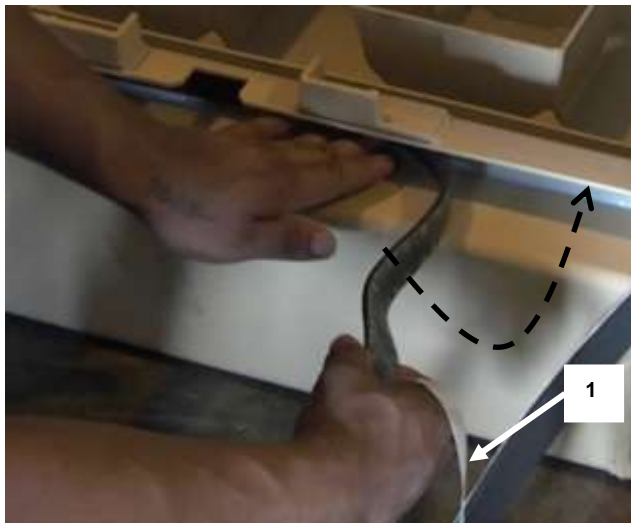

5. Peel back the paper backing (1) as you place the seal in position.
6. Trim or cut the seal when you reach the end of the run.



SEAL LOCATIONS AND POSITIONS

NOTE

Seals should not be stretched, but positioned in a relaxed state.
Always dry fit and trim excess after installation.

LOWER AND TOP CORNER FRAME SEALS

1. Cut the seal to a little oversize for the right and left corner (1).
2. Dry fit to check and trim to size.



3. Peel back the paper backing (2) and apply turbo fuse glue (3) to the surfaces that contact metal



4. Cut, trim and glue two pieces (4) to fit the bottom corners (1)

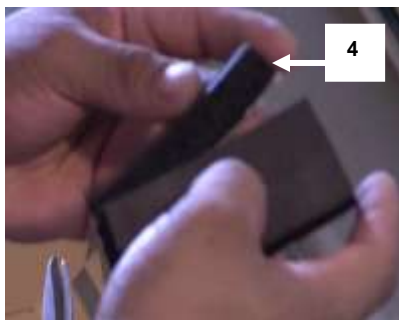

5. Cut a notch (1) and dry fit the bottom corner (2).

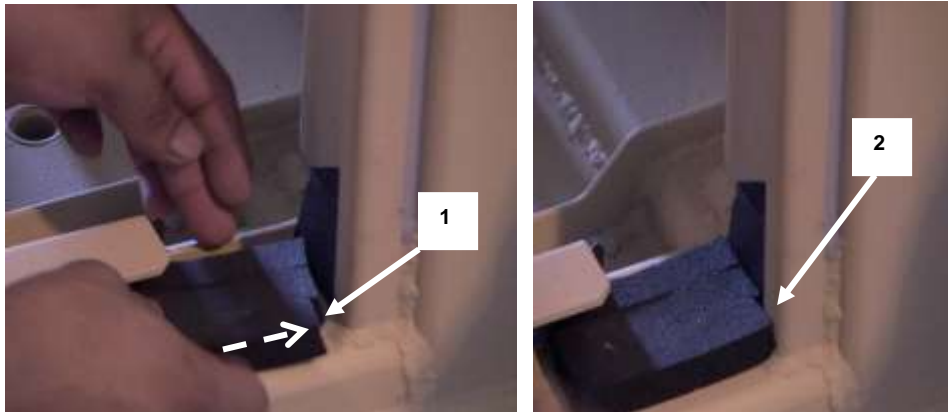

6. Remove the paper backing and apply turbo fuse glue (3) and hold in place until set.
7. Apply a liberal amount of black sealant (4) to the right (5) and left (6) corner frame seals.
8. Apply to the edges then coat all the seal surfaces with sealant (4) using a putty knife.

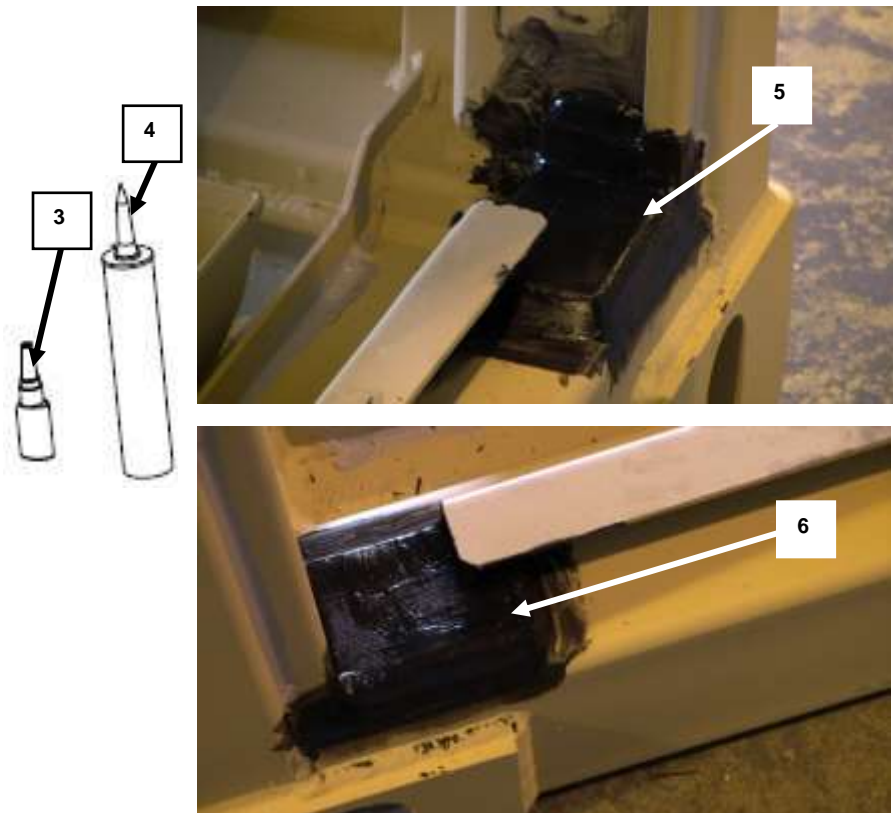

NOTE

The top corner seals left and right are applied and coated in the same fashion.

CAUTION

All seal surfaces must be clean, free of dust, dirt, grease, oil and moisture before applying the seals.
Wipe with clean rags and mineral spirits prior to installing the seals.

UPPER FRAME SEALS

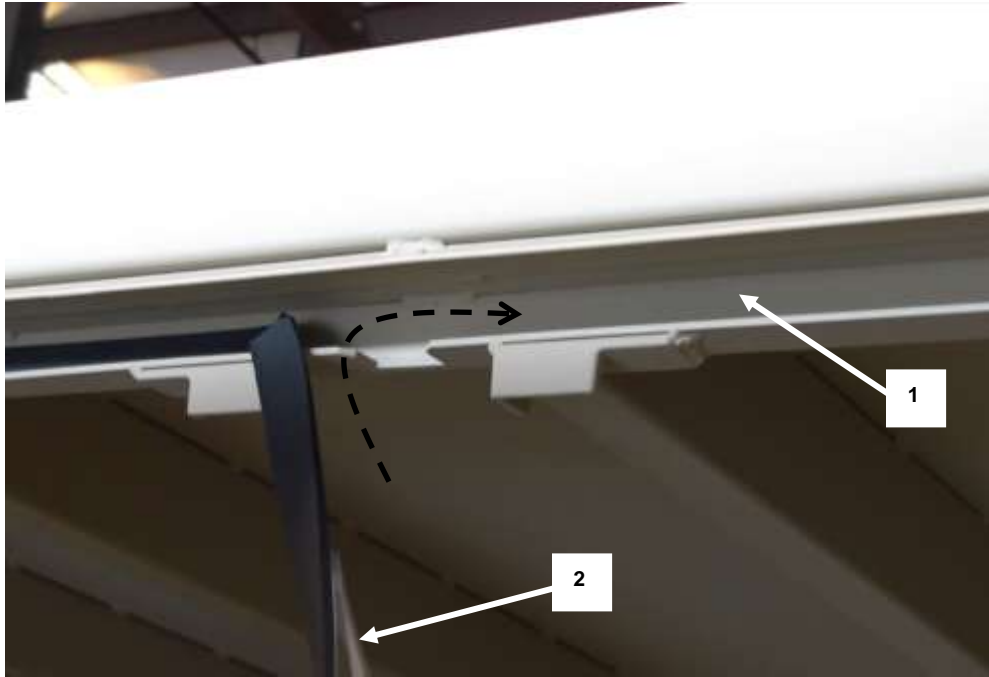

NOTE

Seals should not be stretched, but positioned in a relaxed state.

1. Apply the seal against the back edge of the upper frame (1), removing the paper backing (2) as you go, trim at the end of the run (3).

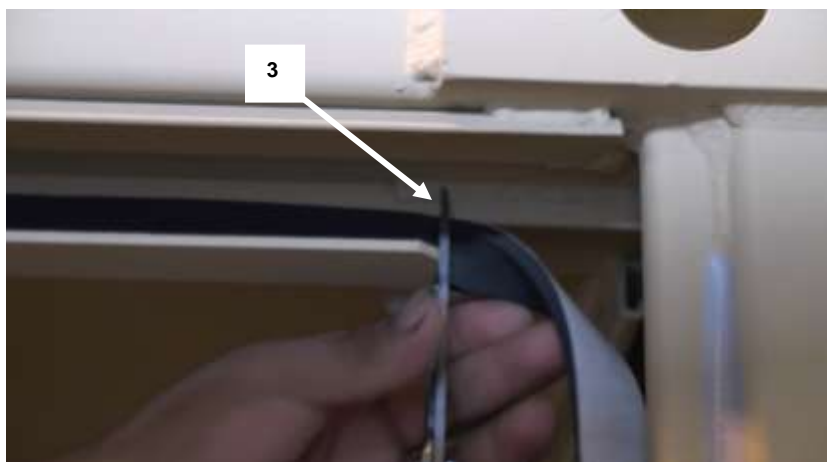

LOWER FRAME SEALS

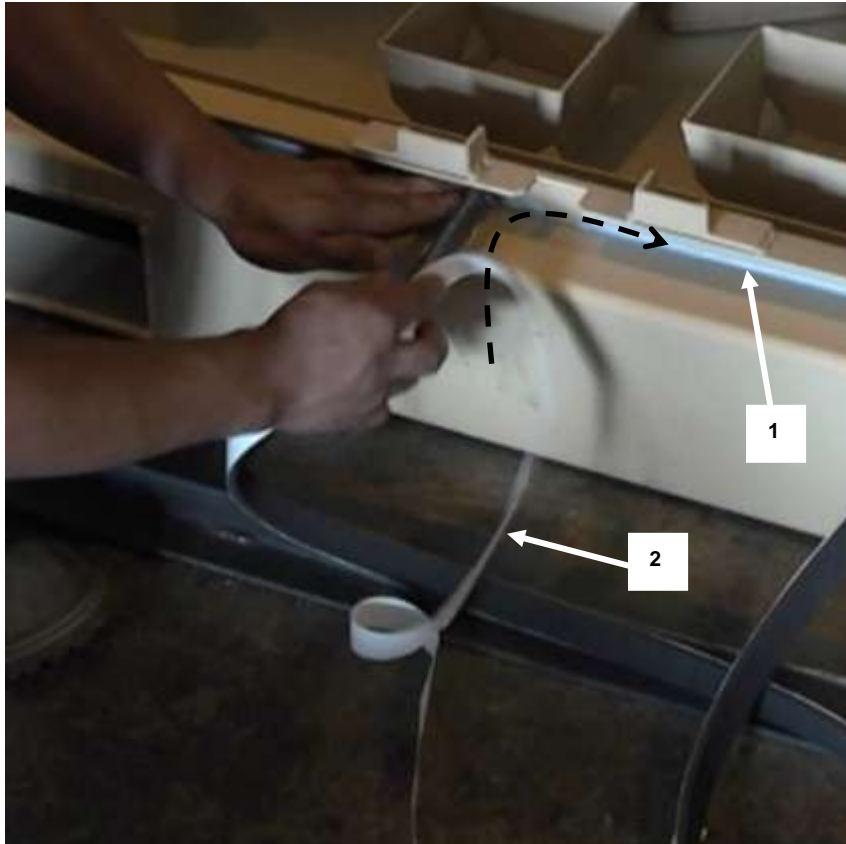

1. The lower frame seal is applied to the back edge (1) in the same fashion as the upper frame seal.
2. Peel off the paper backing (2) as you go, apply the seal and trimmed at the end of the run.

CAUTION

All seal surfaces must be clean, free of dust, dirt, grease, oil and moisture before applying the seals.
Wipe with clean rags and mineral spirits prior to installing the seals.

INNER FRAME EDGE SEALS



1. The left side and right side inner frame seals (1) are applied to the inner edges (2) in the same fashion as the upper frame seal and trimmed at the end of the run (3).



DOOR EDGE SEALS

The hinge side edge seals are crimp type seal (1) on both left and right doors and applied with a rubber mallet.

The right side door center seal is a flat peel and stick type seal (2).

The left side door center seals are crimp type seals (3) applied with a rubber mallet.

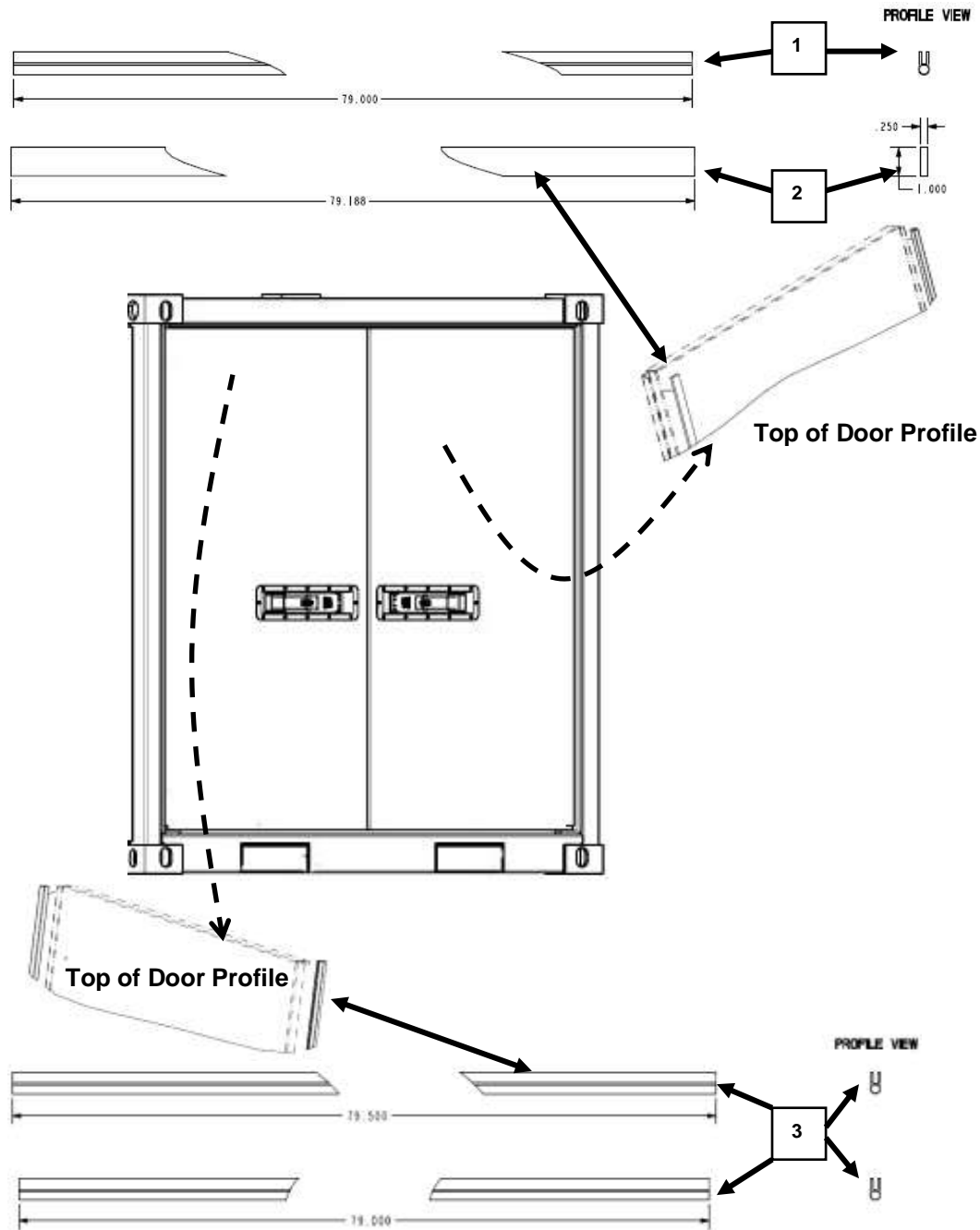

CAUTION

All seal surfaces must be clean and free of dust, dirt, grease, oil and moisture before applying the seals.
Wipe with clean rags and mineral spirits prior to installing the seals.

1. On the center of the right hand door apply the peel and stick seal, removing the paper backing as you go to the end of the run and trim off any excess.

NOTE

Crimp type seals do not require adhesive.

2. Position the crimp type seals (1) on the door edge and tap with a rubber mallet (2) to set the seal in place trim off the excess at the end of the run.

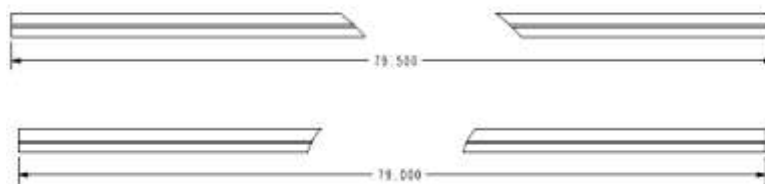
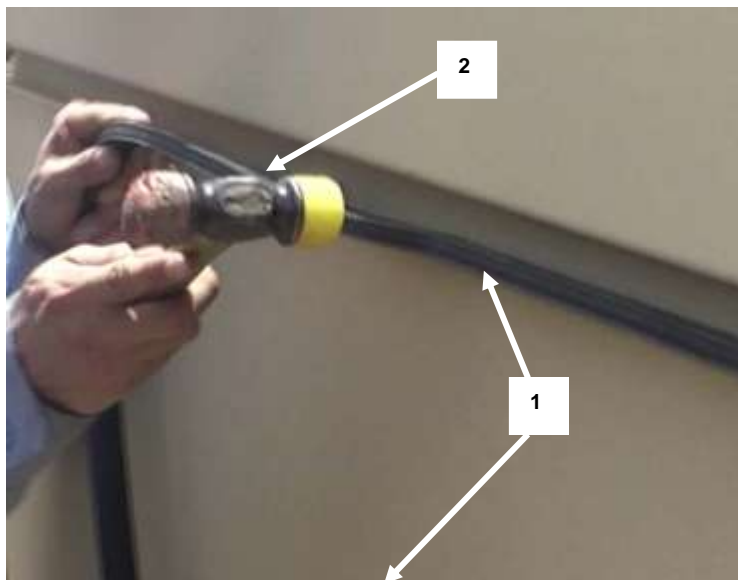

PROFILE VIEW



END OF WORK PACKAGE

This page was intentionally left blank

**FPU SYSTEMS OPERATION MANUAL
(INCLUDING REPAIR PARTS & ACCESSORIES)
FOR
FPU/BOH CARGO CONTAINERS
MODELS FPU-8-2, BOH-CARGO-12-1, BOH-CARGO-6 & FPU-20-1 & FPU-20-2
MAINTENANCE INSTRUCTIONS**

FPU-8-2 and FPU-20-1&2 FOLDING STEPS and Ground Bolt

Inspect, SERVICE, REPLACE

INITIAL SETUP:

Material/Parts

Lubricant

Personnel Required

One

Tools

General Mechanic's Tool Kit/Ladder

References

WP 0005 00-8

Equipment Condition

FPU SYSTEM Set-up

INSPECT

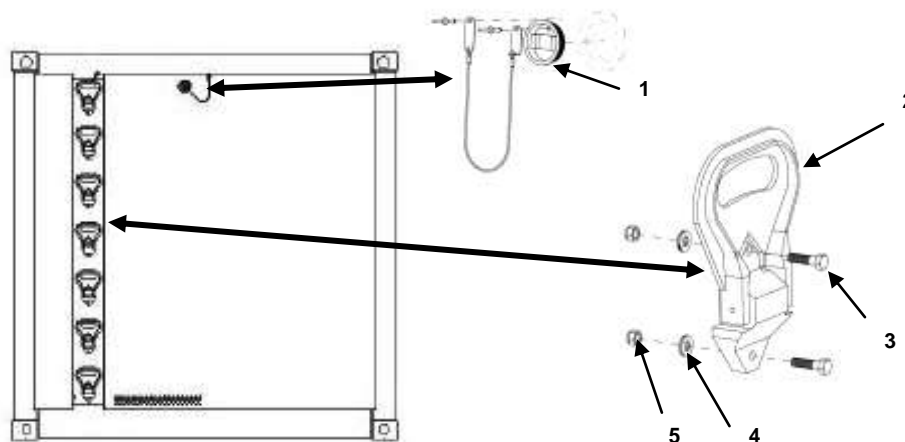

1. Inspect for missing access bung (1) and lanyard attached by two 3/16" pop rivet.
2. Raise and lower each of the steps (2) to ensure they stow and operate
3. Notify unit maintenance of missing, cracked, broken or poorly operating steps (2).
4. Notify unit maintenance of any broken or missing bolts (3) interior nut and washer (4, 5).
5. Inspect for the presents of the ground bolt and washer (6) next to the bottom step.

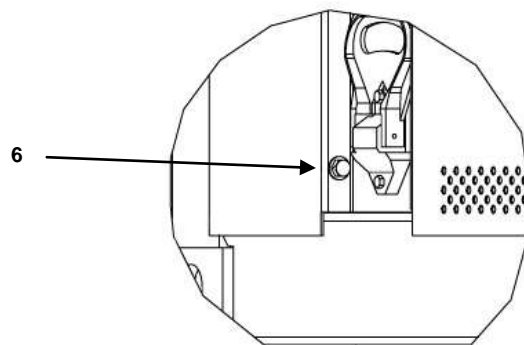

END OF WORK PACKAGE

This page was intentionally left blank

**FPU SYSTEMS OPERATION MANUAL
(INCLUDING REPAIR PARTS & ACCESSORIES)
FOR
FPU/BOH CARGO CONTAINERS
MODELS FPU-8-2, BOH-CARGO-12-1, BOH-CARGO-6 & FPU-20-1 & FPU-20-2
MAINTENANCE INSTRUCTIONS**

BOH-CARGO-12-1 VERTICAL RACK FRAME

INSPECT, SERVICE, REPAIR

INITIAL SETUP:

Materiel/Parts

Rags, Water

Personnel Required

One

Tools

General Mechanic's Tool Kit/Ladder

References

WP 0006 00-8 thru 0006 00-14

Equipment Condition

FPU SYSTEM Set-up

INSPECT

1. Inspect the vertical rack frame (1) for cracks, excessive dents or bending. Report to unit maintenance for repair or replacement.
2. Inspect vertical Rack upper attachment assembly (2) for cracks, excessive dents or bending. Report to unit maintenance for repair or replacement.
3. Inspect vertical rack frame for damaged or missing grip bolts (3). Report to unit maintenance for repair or replacement.

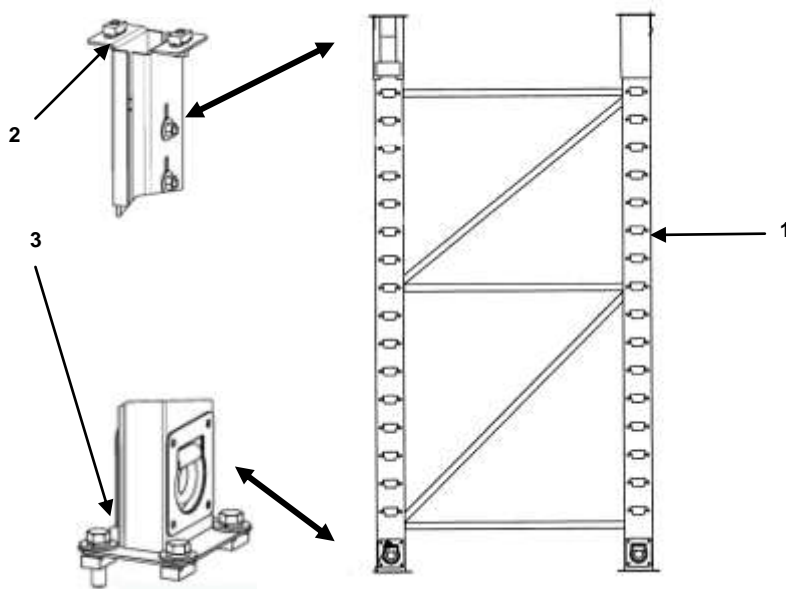

SERVICE

Wipe surfaces using a wet, soapy rag as necessary to keep equipment clean.

REPAIR

1. Remove all drawers/pallets, drawer/pallet ledges that are attached to the vertical rack frame (1) to be replace (refer to WP 0038 00 and 0039 00 for drawer and pallet ledge removal procedures)
2. Remove the 1/2-inch hex head bolts from the upper rack attachment assembly (2) and vertical rack frame base using a 3/4-inch socket with ratchet.
3. Slide the rack upper attachment assembly (2) down and remove vertical rack frame.
4. Insert the repaired/replacement vertical rack frame in the approximate position.
5. Attach upper attachment assembly (2) and vertical rack base with 1/2-inch hex head bolts (Apply Loctite 262 to bolt threads). Hand-tighten only.
6. Reattach drawer/pallet ledges in their desired positions (refer to WP 0035 00) for drawer and pallet ledge install procedures.
7. If the vertical rack frame is being installed on a pallet-configured container use the pallet ledge stabilizer to obtain proper spacing by attaching but not tightening the stabilizer.
8. For parts configured container use the following table to obtain proper spacing:

30-Inch Drawers	29-7/8 Inches
48-Inch Drawers	47-5/8 Inches

9. Tighten all 1/2-inch bolts on the rack upper attachment (2) and vertical rack frame base (3) using a 3/4-inch socket with ratchet.
10. Reattach drawers/pallets to vertical rack frame (refer to WP 0035 00) for drawer and pallet install procedures).

END OF WORK PACKAGE

**FPU SYSTEMS OPERATION MANUAL
(INCLUDING REPAIR PARTS & ACCESSORIES)
FOR
FPU/BOH CARGO CONTAINERS
MODELS FPU-8-2, BOH-CARGO-12-1, BOH-CARGO-6 & FPU-20-1 & FPU-20-2**

BOH-CARGO-12-1 FLOOR PLATE ADAPTER PADS

INSPECT, REPLACE, REPAIR

INITIAL SETUP:

Materiel/Parts

Personnel Required

One

Tools

Putty knife and contact cement

References

WP 0006

Equipment Condition

FPU SYSTEM Set-up

INSPECT

Inspect the Floor Plate Pads (1 and 2) for presence, debris, dirt and proper fit.

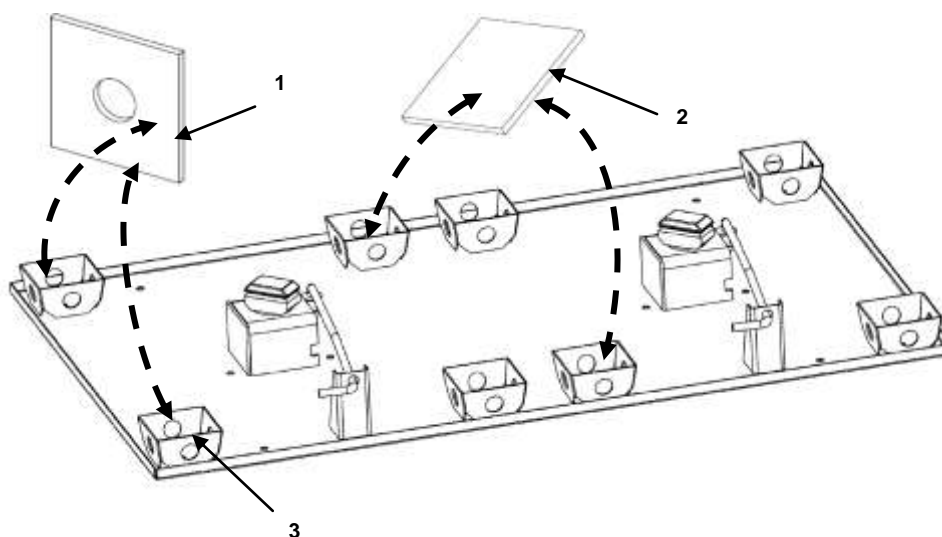

REPLACE

Replace the four corner pads (1) and the four center pads, if dry rotted, damaged.

REPAIR

1. Using a putty knife scrap out the old material, clean the interior pocket area (3) and glue in the new pads.

END OF WORK PACKAGE

This page was intentionally left blank

**MAINTENANCE INSTRUCTIONS
FPU SYSTEMS OPERATION MANUAL
(INCLUDING REPAIR PARTS & ACCESSORIES)
FOR
FPU/BOH CARGO CONTAINERS
MODELS FPU-8-2, BOH-CARGO-12-1, BOH-CARGO-6 & FPU-20-1 & FPU-20-2
BOH-CARGO-12-1 DRAWER ASSEMBLY**

INSPECT, SERVICE, REPLACE**INITIAL SETUP:****Materiel/Parts**

Rags, Water

Personnel Required

One

Tools

General Mechanic's Tool Kit

References

WP 0006 00-8 thru 0006 00-14

Equipment Condition

FPU SYSTEM Set-up

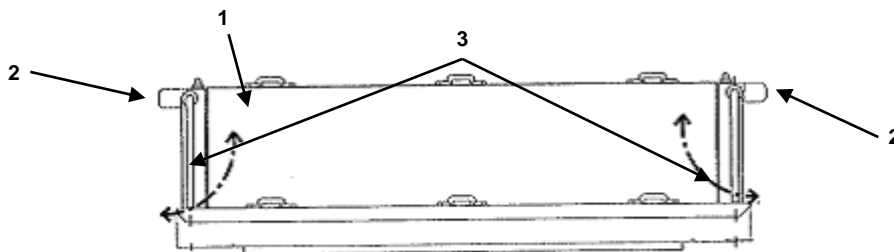
INSPECT

1. Inspect drawer (1) for cracks, excessive dents or sagging. Notify Direct Support if any repairs are necessary. Replace drawer if necessary.
2. Open and close drawer assemblies (1) following steps outlined in (WP 0006 00) to ensure proper operation (opens/closes without any binding, drawer stops work properly). Notify Direct Support if any repairs are necessary.

SERVICE

1. Remove debris and trash from drawer (1) as necessary.
2. Wipe Drawer (1) interior and exterior with a wet rag as required.

REPLACE

Replace drawer assembly if required. Drawer must be replaced if the locking tabs (2) or handles (3) fail to hold the drawer in the open or closed position and if there is excessive sagging or bending.

To replace:

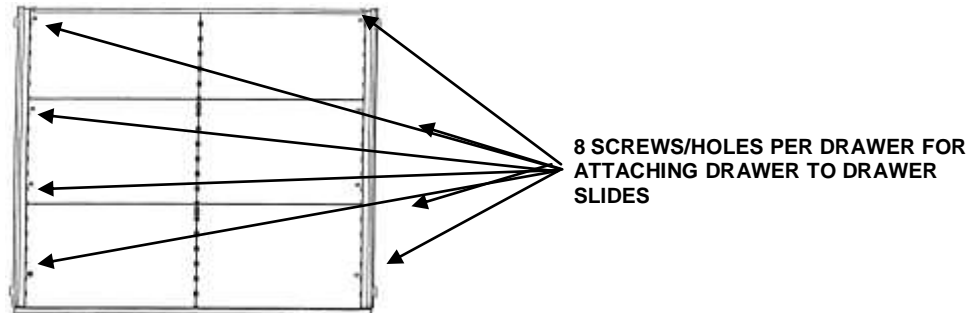

1. Fully extend drawer to the open position. (If drawer will not stay in the open position this task will require two people. One to hold the drawer in the extended position and the other to perform drawer removal task).
2. Remove all stored material from drawer.
3. Remove eight ¼-inch screws located in the bottom of the drawer at either side.
4. Lift drawer from slide ledge (4).

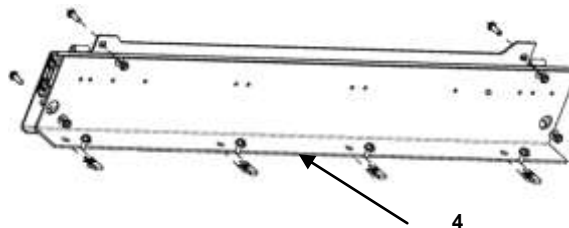

CAUTION

If a bolt is lost or damaged beyond use, obtain a replacement. Do not install with less than the proper number of bolts or equipment damage may occur.

5. Position new drawer on the slide ledge being careful to align mounting holes.
6. Install eight ¼-inch screws and slightly hand-tighten.
7. After hand tightening, push drawer completely closed and pull back to the full open position to allow drawer to seat into its proper location on the drawer slide ledge.
8. Being careful not to over tighten, secure the eight ¼-inch mounting screws.

END OF WORK PACKAGE

**MAINTENANCE INSTRUCTIONS
FPU SYSTEMS OPERATION MANUAL
(INCLUDING REPAIR PARTS & ACCESSORIES)
FOR
FPU/BOH CARGO CONTAINERS
MODELS FPU-8-2, BOH-CARGO-12-1, BOH-CARGO-6 & FPU-20-1 & FPU-20-2
BOH-CARGO-12-1 DRAWER SLIDE**

INSPECT, SERVICE, REPLACE**INITIAL SETUP:****Materiel/Parts**

Rags, Water

Personnel Required

Two

Tools

General Mechanic's Tool Kit

References

WP 0006 00-8 thru 0006 00-14

Equipment Condition

FPU SYSTEM Set-up

INSPECT

1. Inspect drawer BOH CARGO -12-1 drawer slides (1) for operation, missing hardware per WP 0006.
2. Inspect drawer BOH CARGO -12-1 drawer slides (1) for dirt/debris that would affect performance.

SERVICE

Wipe surfaces as necessary to keep equipment clean.

REPLACE

1. Fully extend drawer to the open position. (If drawer will not stay in the open position this task will require two people. One to hold the drawer in the extended position and the other to perform drawer removal task).
2. Remove all stored materiel from drawer.

CAUTION

If a bolt is damaged beyond use, obtain a replacement. Do not install with less than the proper number of bolts or damage to equipment may occur.

3. Loosen but do not remove the four ¼-inch nuts on the carriage bolts using a ¼-inch socket with ratchet and extension.

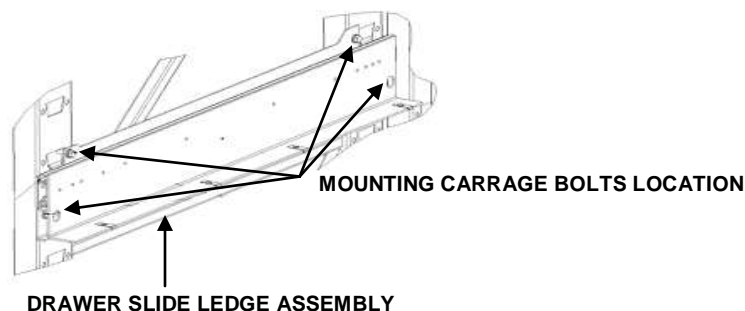

4. Slide ledges are retained on the vertical rack frame by four bayonet tabs protruding into the windows of the vertical rack frame. This requires the ledge to be loosened from the vertical rack frame. While one person securely holds the slide ledge, the second person applies an upward force by tapping the underside of the slide ledge at the attached points with a 2 x 4 soft wooden block or similar material.
5. Place the drawer slides ledges in their desired positions by inserting the bayonet tabs into the vertical rack frame windows while aligning the four carriage bolts into their appropriate slots. Slots are tear drop to retain the head of the 1/4" carriage bolts. Tap down on the ledge a 2 X 4 soft wooden block or similar material. Ensure the carriage bolts drop completely down in the slots.

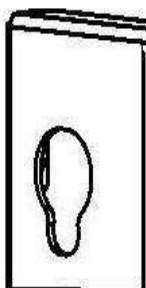

TEARDROP SLOT

6. Apply Loctite 262 red to the four 1/4-inch on the carriage bolts.
7. Tighten drawer slide ledge to rack frame by tightening the four 1/4 -inch carriage bolt nuts bolts using a 1/4 -inch socket with ratchet and extension.
8. Position new drawer on the slide ledge being careful to align mounting holes.
9. Install eight 1/4-inch screws and slightly hand-tighten.
10. After hand tightening, push drawer completely closed and pull back to the full open position to allow drawer to seat into its proper location on the drawer slide ledge.
11. Being careful not to over tighten, secure the eight 1/4-inch mounting screws.
12. Reinstall drawer in accordance with WP 0006 00.

END OF WORK PACKAGE

**MAINTENANCE INSTRUCTIONS
FPU SYSTEMS OPERATION MANUAL
(INCLUDING REPAIR PARTS & ACCESSORIES)
FOR
FPU/BOH CARGO CONTAINERS
MODELS FPU-8-2, BOH-CARGO-12-1, BOH-CARGO-6 & FPU-20-1 & FPU-20-2
BOH-CARGO-12-1 PALLET**

INSPECT, SERVICE, REPLACE**INITIAL SETUP:****Materiel/Parts**

Rags, Water

Personnel Required

One

References**Equipment Condition**

FPU SYSTEM Set-up

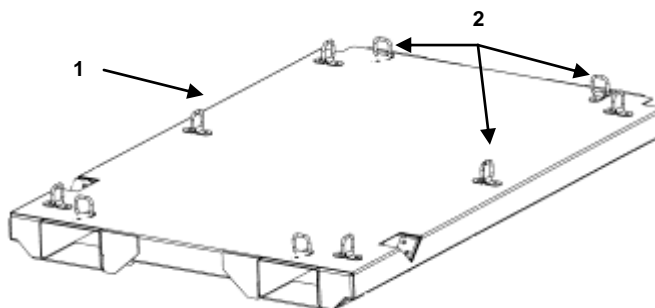
INSPECT

1. Inspect pallet (1) for cracks, excessive dents or sagging. Report to Direct Support maintenance for repair or replacement.
2. Inspect pallet for missing or damage D-rings (2). Report to Unit maintenance for repair or replacement.

SERVICE

Wipe surfaces as necessary to keep equipment clean.

REPLACE

Refer to the pallet operation steps in WP 0006 for replacement of pallets.

END OF WORK PACKAGE

This page was intentionally left blank

**MAINTENANCE INSTRUCTIONS
FPU SYSTEMS OPERATION MANUAL
(INCLUDING REPAIR PARTS & ACCESSORIES)
FOR
FPU/BOH CARGO CONTAINERS
MODELS FPU-8-2, BOH-CARGO-12-1, BOH-CARGO-6 & FPU-20-1 & FPU-20-2
BOH-CARGO-12-1 PALLET LEDGE**

INSPECT, SERVICE, REPLACE, REPAIR

INITIAL SETUP:

Materiel/Parts

Rags, Water

Personnel Required

One, General Mechanic's Tool Kit

References

WP 0006 00-8 thru 0006 00-14

Equipment Condition

FPU SYSTEM Set-up

INSPECT

1. Inspect pallet ledges (1) for cracks or excessive bends. Report to Direct Support for repair.
2. Inspect pallet ledges for proper operation of cam locks and missing hardware.
3. Inspect pallet ledges for dirt/debris that would affect performance.

SERVICE

1. Wipe surfaces and cam lock mechanism as necessary.
2. Lubricate locking rod and cam locks as necessary (refer to WP 0006 00).

REPLACE

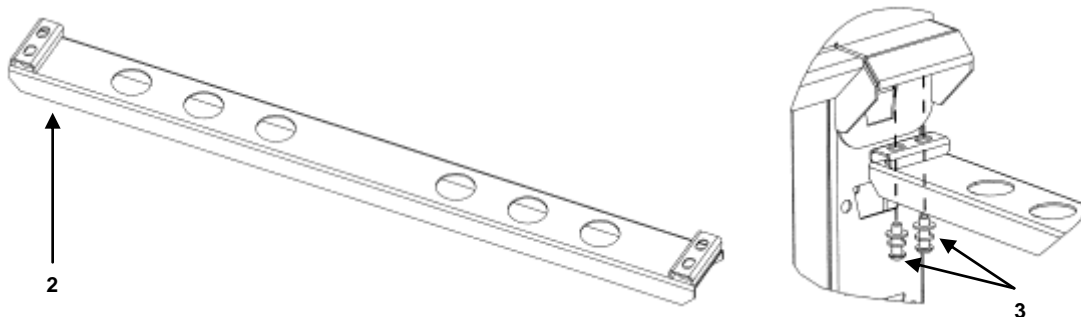

1. Remove pallet on ledge (1) to be replaced and any pallets located above a below to allow access.
2. Remove front and rear horizontal stabilizers (2) by removing the eight 3/16-inch hex head drive sockets and 3/8-inch ratchet with extension.
3. Loosen but do not remove the ten carriage bolt nuts using 1/4 -inch socket and ratchet with extension from the two pallet ledges on the vertical rack frame.

CAUTION

If a bolt is damaged beyond use, obtain a replacement. Do not install with less than the proper number of bolts or damage to equipment may occur.

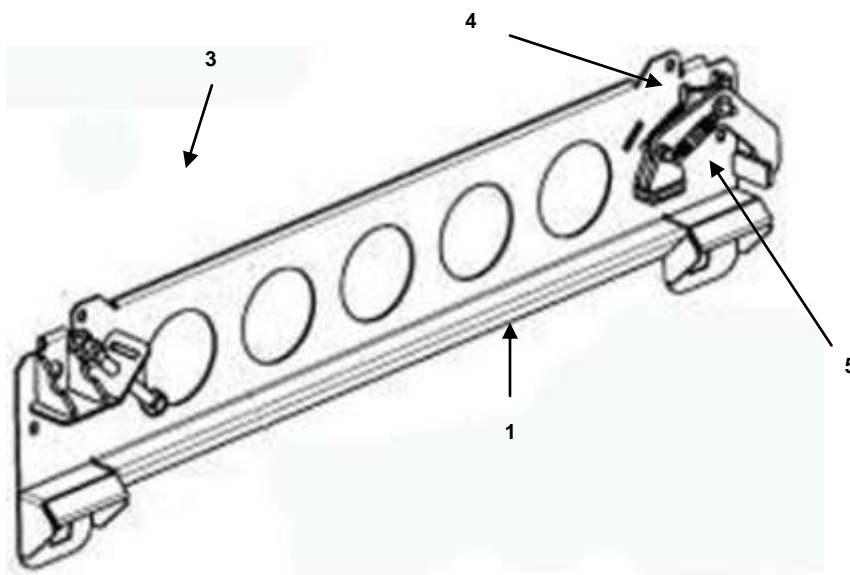

4. Pallet ledges (1) ledges are retained on the vertical rack frame by ten ¼-inch carriage bolts and four bayonet tabs protruding into the windows of the vertical rack frame. This requires the ledge to be loosened from the vertical rack frame. While one person securely holds the pallet ledge, the second person applies an upward force by tapping the under side of the ledge at the attached point with a 2 X 4 soft wooden block or similar material.
5. Place new pallet ledges in their desired positions by inserting the bayonet tabs into the vertical rack frame windows while aligning the ten carriage bolts into their appropriate slots. Ensure that pallet ledges are at same height in the vertical rack frame. Ensure all bayonet tabs have engaged the vertical rack frame windows before tapping into place. Tap down on the ledge with a 2 X 4 soft wooden block or similar material. Ensure the carriage bolts drop completely down in the slots.
6. Apply Loctite 262 red to the ten ¼-inch on the carriage bolts.
7. Tighten the ten carriage bolt nuts using a ¼-inch socket, ratchet and extension.
8. Reinstall rear pallet ledge horizontal stabilizer with the four Allen bolts using 3/16-inch hex head driver socket and 3/8-inch ratchet with extension.
9. Reinstall front pallet ledge horizontal stabilizer with the four Allen bolts using 3/16-inch hex head driver socket and 3/8-inch ratchet with extension.
10. Reinstall pallet.

REPAIR

1. To repair the pallet ledge cam lock (5) the pallet ledge will have to be removed. To remove the pallet ledge (1) to be repair, follow steps 1 through 9 above.
2. Remove the 1/2-inch x 5/8-inch cam shoulder bolt and 1/2-inch lock nut using a 1/4-inch Allen wrench and 9/16-inch socket and ratchet.
3. Detach spring from pallet ledge.
4. Attach spring of the new cam lock assembly to the pallet ledge.
5. Attach new cam lock assembly to pallet ledge using the 1/4-inch Allen wrench and 9/16-inch socket and ratchet.
6. Attach cam lock to pallet ledge using 1/4-inch Allen wrench and 9/16-inch socket and ratchet.
7. Reinstall pallet ledge following steps 4 through 8 above.

END OF WORK PACKAGE

This page was intentionally left blank

**MAINTENANCE INSTRUCTIONS
FPU SYSTEMS OPERATION MANUAL
(INCLUDING REPAIR PARTS & ACCESSORIES)
FOR
FPU/BOH CARGO CONTAINERS
MODELS FPU-8-2, BOH-CARGO-12-1, BOH-CARGO-6 & FPU-20-1 & FPU-20-2
FPU MODULE LOCK DEVICE**

INSPECT, SERVICE, REPLACE

INITIAL SETUP:

Materiel/Parts

Lubricant (see Table 2 Lubrication in WP 0015)

Personnel Required

Two

References

WP 0012 00 WP 0007 00

Equipment Condition

FPU SYSTEM Set-up

INSPECT

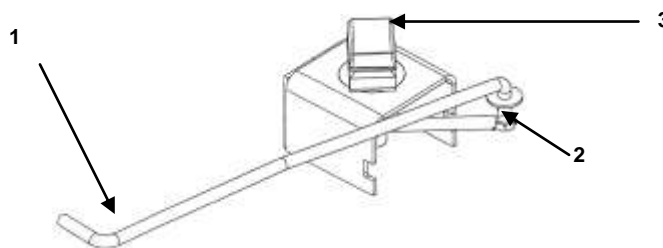

1. Pull and push to check lock device motion (3).
2. Inspect cotter pin (2) and handle operation.

SERVICE

1. Pull the Red handle ISO locking arm (1) out, into unlocked position.
2. Remove Module using appropriate MHE, lift module to clear cradles.
3. Lubricate moving parts.
4. Pick up module with drawers facing forklift.
5. Position module over cradles.
6. Lower module into cradles.
7. Push the Red handle ISO locking arm (1) into the locked position.

REPLACE

Replace modules per inserting module steps WP 0007 00.

END OF WORK PACKAGE

This page was intentionally left blank

**MAINTENANCE INSTRUCTIONS
FPU SYSTEMS OPERATION MANUAL
(INCLUDING REPAIR PARTS & ACCESSORIES)
FOR
FPU/BOH CARGO CONTAINERS
MODELS FPU-8-2, BOH-CARGO-12-1, BOH-CARGO-6 & FPU-20-1 & FPU-20-2
FPU-8-2, BOH-CARGO-12-1, BOH-CARGO-6 CONNECTOR DEVICES**

INSPECT, SERVICE, REPLACE**INITIAL SETUP:****Materiel/Parts**

None

Personnel Required

Two (Plus one Supervisor)

Tools

General Mechanic's Tool Kit, Forklift, Ladder

References

WP 0005 00 and WP 0008 00

Equipment Condition

FPU-8-2/CARGO-12-1/BOH 6 Set-up

INSPECT**NOTE**

Bridge Locks and Restraint Locks (1) are applicable to the FPU-8/BOH-6/FPU-8 only.
The horizontal interconnector (2) only applies to the FPU-8/ FPU-12 combination container.

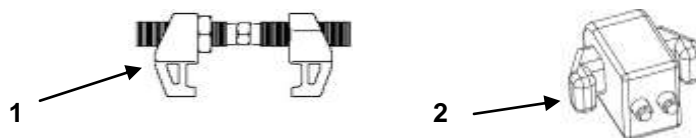
**CAUTION**

Review weight limitation tables WP 0002 00-6

1. Separate FPU SYSTEM containers per WP 0005 00 and WP 0008 00.
2. Inspect Bridge Locks (1), horizontal interconnector (2) for lubrication and proper operation.

SERVICE

1. Clean using hot soapy water and lubricate the treads of the bridge locks (1) (refer to Table 2 in WP 00015 00).
2. Clean using hot soapy water and lubricate bolt treads on horizontal inter-connectors (3) (refer to Table 2 in WP 00015 00).
3. Clean using hot soapy water and lubricate transverse stabilizer tensioning blocks bolt treads (refer to Table 2 in WP 00015 00).

4. Clean using hot soapy water and lubricate loading rail connectors (refer to Table 2 in WP 0012 00).

Bridge Locks

1. Clean bridge lock threads using a degreaser.
2. Lubricate the threads of the bridge locks (1) (refer to Table 2 in WP 0012 00).

Horizontal Inter-connectors

1. Disassemble using 9/16-inch and 3/4-inch wrenches.
2. Thoroughly clean using a degreaser.
3. The horizontal inter-connectors have operating threads and pivot points that must always be coated with waterproof grease to insure trouble-free operation. Completely fill the inside cavity of the inter-connector with Molykote (refer to table 2 in WP 0015 00).
4. Rotate drive studs until threads are full out.
5. Coat exposed threads with the same grease.
6. Move studs in and out a few times to evenly distribute grease.
1. In long-term exposure to corrosive environments, it is suggested the entire connection be covered externally to prevent the loss of interior lubricant..

REPLACE

Connector components must be replaced if damaged. Remove and replace connector components as per WP 0005 00 and WP 0008 00.

END OF WORK PACKAGE