

CHAPTER 2
OPERATOR INSTRUCTIONS

This page was left intentionally blank

**OPERATOR INSTRUCTIONS
FPU SYSTEMS OPERATION MANUAL
(INCLUDING REPAIR PARTS & OPTIONAL ACCESSORIES)**

**FOR
MODELS FPU-8-2, BOH-CARGO-12-1, BOH-CARGO-6, FPU-20-1 & FPU-20-2
THEORY OF OPERATION**

FPU 8-2, BOH-CARGO-12-1 BOH-CARGO-6 and FPU-20-1 & 2

The FPU-8-2/BOH-CARGO-12-1 (Combination) when joined in a twenty-foot configuration using our ISO certified Horizontal Interconnectors is capable of transport via the LHS or PLS utilizing a PLS flat-rack and commercial/MSC ships. This container system consists of a 7-foot long container (FPU-8-2) and a 12-foot 9-inch long container that when connected together with our ISO certified connectors form an 8'W x 92-inchH x 20'L ISO certified (Type 1C) container. This feature allows the container to be separated and move when heavy lift MHE is limited or unavailable.

FPU-8-2 Container

The FPU-8-2 container can be configured to accommodate up to four standard or specialized modules, up to two Glide-Out storage racks with pullout shelves or a combination of these storage aids. The FPU-8-2 consists of 2 pocket doors (both sides) that retracts into the container, retractable roof access steps, forklift pockets and a convection type ventilation system.

BOH-CARGO-12-1 Container

The container can be configured to accommodate up to two pallet racks with special pallets, up to two parts racks with drawers or up to sixteen tie-down rings or a combination of these storage aids. It consists of 2 bi-fold barn doors (both sides), forklift pockets and a convection type ventilation system.

FPU-20-1 & FPU-20-2 Containers

The FPU-20-1& FPU-20-2 containers can be configured to accommodate up to four standard or specialized modules, up to two Glide-Out storage racks with pullout shelves or a combination of these storage aids. The FPU-20-1 and FPU-20-2 consists five pocket doors (each side) that retract into the container, retractable roof access steps, forklift pockets and a convection type ventilation system.

BOH-CARGO-6 Bulk Container

NOTE

The BOH FPU Module systems do not apply to the BOH-CARGO-6 container.

The BOH-CARGO-6 is a general-purpose side load bulk cargo container and is not ISO certified. The single door is equipped with exterior hinges and recessed cam type locking handle and comes with adjustable sectional shelves. The BOH-CARGO-6 measures 96"W x 72"L x 92"H with ISO corner blocks. It has a maximum capacity of 10,000 lbs and it can be fitted with additional shelves as required. It is designed as a stand-alone utility container or to fit between two (2) FPU-8 series containers to completely fill the 20 ft. configuration. The BOH-CARGO-6 can be stacked 3 high.

END OF WORK PACKAGE

This page was left intentionally blank

**OPERATOR INSTRUCTIONS
FPU SYSTEMS OPERATION MANUAL
(INCLUDING REPAIR PARTS & OPTIONAL ACCESSORIES)**

**FOR
MODELS FPU-8-2, BOH-CARGO-12-1, BOH-CARGO-6, FPU-20-1 & FPU-20-2
PREPARATION FOR MOVEMENT AND TRANSPORT**

INITIAL SETUP:

FPU Packed out

Maintenance Level

Operator / Crew / MHE Operator

Personnel Required

Three (plus one supervisor)

PREPARATION FOR MOVEMENT

This work package provides step-by-step instructions for the download, set-up and movement of FPU containers.

WARNING



If a container is dropped during transit movement, extreme care should be taken when opening the doors to preclude material from falling on and injuring personnel.

Site Requirements

WARNING



Container must be operated on level ground. To maintain control, consider the ground surface conditions for adequate traction, such as mud, snow, ice, sand.

If the container is transported on the PLS trailer utilizing a PLS Flat-rack, the selected site must have a minimum of 20 ft x 25 ft of flat level, open space to provide setup space for the container. Care should be taken to ensure that no overhead obstructions interfere with the offload of the container and Flat-rack from the PLS.

CAUTION

Flood plane conditions should be considered since the containers have vent holes for the ventilation system that are not designed to withstand flooding. If in doubt, consult the operations supervisor or commander.

PREPARING FPU FOR USE

Except when using a Boh FPU-TS trailer, FPU container systems are designed for a ground-based operation, never attempt to access the containers when the containers are on any transporting equipment or not downloaded and established in an operational site. Once downloaded, the FPU is ready for immediate use in most circumstances. If using a Boh FPU-TS trailer, ensure all pullout walkways are fully extended, assembled and safety strap has been erected.

OPERATION OF ROOF ACCESS SYSTEM

NOTE

The roof access system is not applicable to the BOH-CARGO-12-1 containers. When connecting a FPU-8-2 to a BOH-CARGO-12-1 ensure folding steps on the FPU-8-2 are oriented to the outside end to allow their use to access the roof during installation of the horizontal interconnectors.

The Roof Access System consists of seven retractable steps located on the end of the FPU-8-2, FPU-20-1 & FPU-20-2 containers.

WARNING



Fall hazards exist when climbing onto, returning from or working from the top of the container. Always maintain three points of contact to the roof access steps and FPU container when climbing onto the FPU container. Never move, step, or walk backwards when working on top of the system. All movement should be in the forward direction. A fall can occur if the worker loses concentration and steps backwards off of the edge. Stand erect only if necessary and only away from the edge. Working from a kneeling position helps reduce the threat of a fall.

BOH FPU-8-2/, FPU-20- 1 & FPU-20-2 containers are marked with the following ISO marking. Its' meaning is provided below:

WARNING



Overhead power lines and obstructions can cause serious injury or damage to property. Forklift operators, truck drivers and ground guides should always clear overhead when loading, unloading or accessing the roof of the containers.

ROOF ACCESS SYSTEM

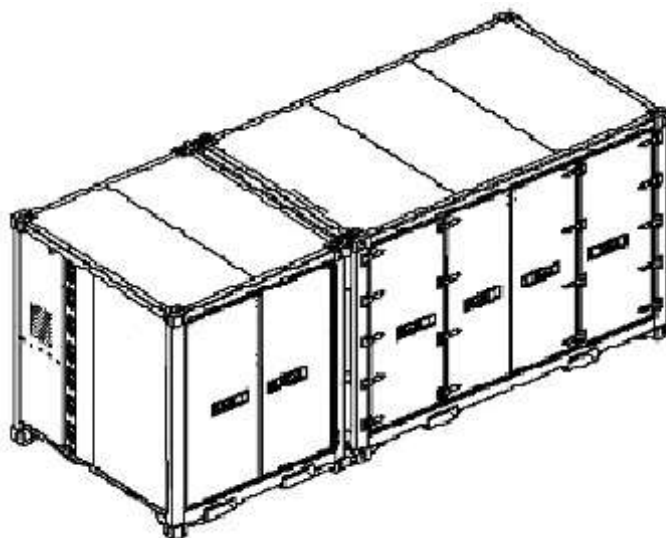

NOTE

Always position the FPU-8-2 with the folding steps on the end to gain access to the roof.
The folding steps are only applicable to the FPU-8-2, FPU-20- 1 & FPU-20-2

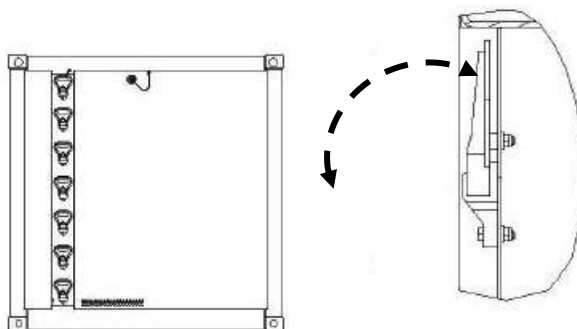

DISCONNECTING FPU-8-2 AND BOH-CARGO-12-1 CONTAINERS**NOTE:**

Not applicable for Boh-Cargo-6, FPU-20-1 & FPU-20-2 containers. Two people and a forklift operator are required to perform this task. The following equipment will be required: One chain rated 20K or higher, one 9/16-inch thin wall socket with ratchet, and a forklift or heavy-duty vehicle with pintle hook.

1. Select a firm, level road surface to disconnect the containers.
2. Access the roof via the roof access system located on the rear end of the FPU-8-2 to loosen the horizontal interconnectors.

**WARNING**

Overhead power lines and obstructions can cause serious injury or damage to property. Forklift operators, truck drivers and ground guides should always clear overhead when loading, unloading or accessing the roof of the containers.

WARNING

Fall hazards exist when climbing onto, returning from or working from the top of the container. Always maintain three points of contact to the ladder and FPU container when climbing onto the FPU container. Never move, step, or walk backwards when working on top of the system. All movement should be in the forward direction. A fall can occur if you lose concentration and step backwards off of the edge. Stand erect only if necessary and only away from the edge. Working from a kneeling position helps reduce the threat of a fall.

NOTE:

There are two 9/16" adjuster bolts located on the side of the horizontal interconnectors. One is close to the FPU-8-2 side and the other close to the BOH-CARGO-12-1 side. Loosen only the BOH-CARGO-12-1 side horizontal interconnector bolts.

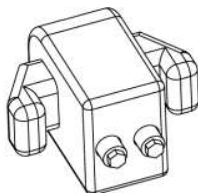

**9/16-INCH HEX HEAD LOCKING
ADJUSTMENT BOLTS**

- Using the 9/16-inch socket and ratchet retract fully the adjuster bolts on the two top horizontal interconnectors (BOH-CARGO-12-1 side).

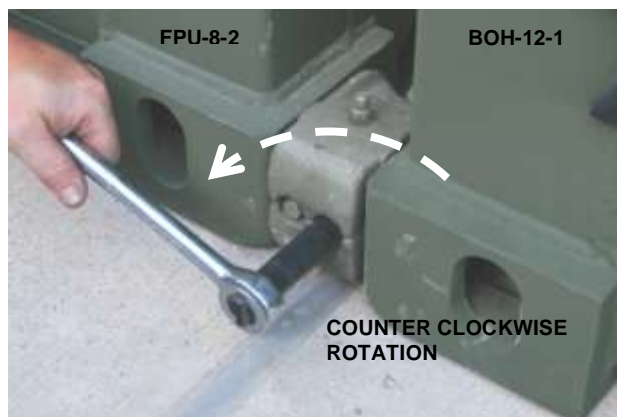

- Return to ground via roof access system at the end of the FPU-8-2.
- Using the 9/16-inch socket and ratchet retract fully adjuster nuts on the two lower horizontal interconnectors (Boh-Cargo-12-1 side).
- Connect the chain rated to the two bottom corner blocks of the FPU-8-2 container. The chain should be long enough to allow enough slack for it to be connected to the pintle hook of the towing vehicle once connected to the FPU-8-2 container.
- Using a ground guide, position the towing vehicle with the pintle hook facing the center of the FPU-8-2 container. Ensure the towing vehicle is positioned in such a way as to be able to pull the FPU-8-2 container away from the container in evenly and in a straight line.
- Turn towing vehicle off and set the emergency brake.
- Connect the chain to the pintle hook of the towing vehicle.
- Using two ground guides (one positioned in the front and to one side of the towing vehicle and one at the side and with a visual of the container connection) restart the towing vehicle, release emergency brake and slowly pull forward until containers are separated (approximately 2-feet apart).

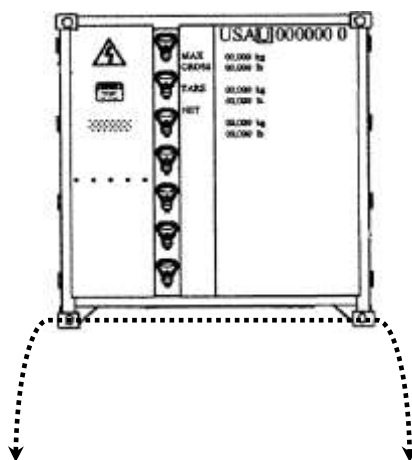

WARNING

Ground guides and the HME operator must maintain direct line of sight and insure that personnel are clear of the containers during this operation.

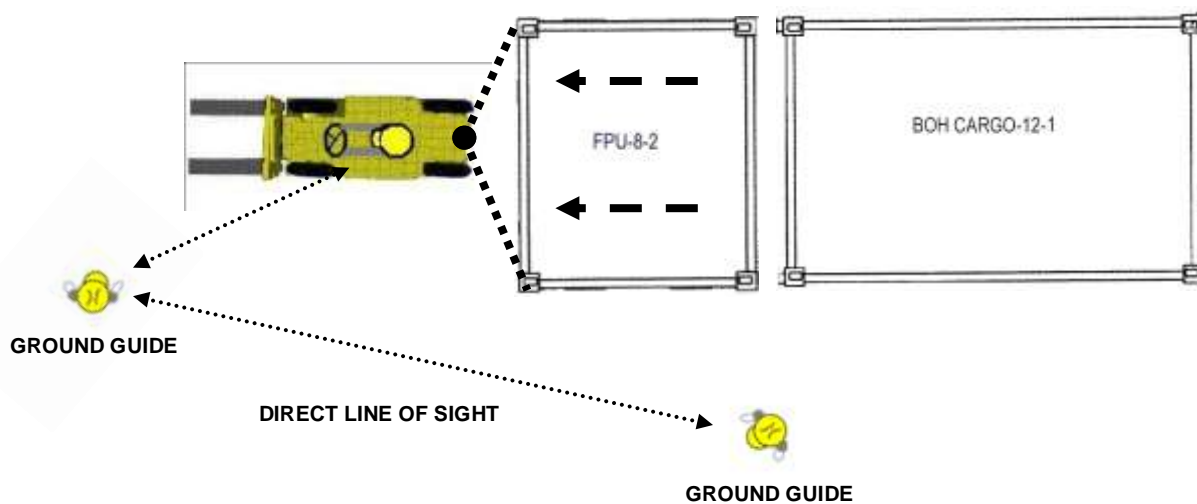

11. Using two ground guides reverse the towing vehicle and back up towards the container until enough slack is in the chain to allow it to be disconnected from the towing vehicle.
12. Turn towing vehicle off and set emergency brake.
13. Disconnect the chain from the towing vehicle and FPU-8-2 corner blocks.
14. Return to the roof via the roof access system located on the FPU-8-2 to remove the upper horizontal interconnectors.
15. Return to ground via roof access system at the end of the FPU-8-2.
16. Completely retract adjuster nuts on the two lower horizontal interconnectors (BOH-CARGO-12-1) and remove and store in a safe place.

CONNECTING FPU-8-2/BOH-CARGO-12-1 CONTAINERS**NOTE:**

Not applicable for Boh-Cargo-6, FPU-20-1 & FPU-20-2 containers.

Two people and a forklift operator are required to perform this task. The following equipment will be required: One 9/16-inch thin wall socket with ratchet, one 6" x 6" x 5' section of wood blocking and a forklift.

BOH FPU-8-2/BOH-CARGO-12-1 containers are connected using four horizontal interconnectors on the ISO corner blocks of the containers.

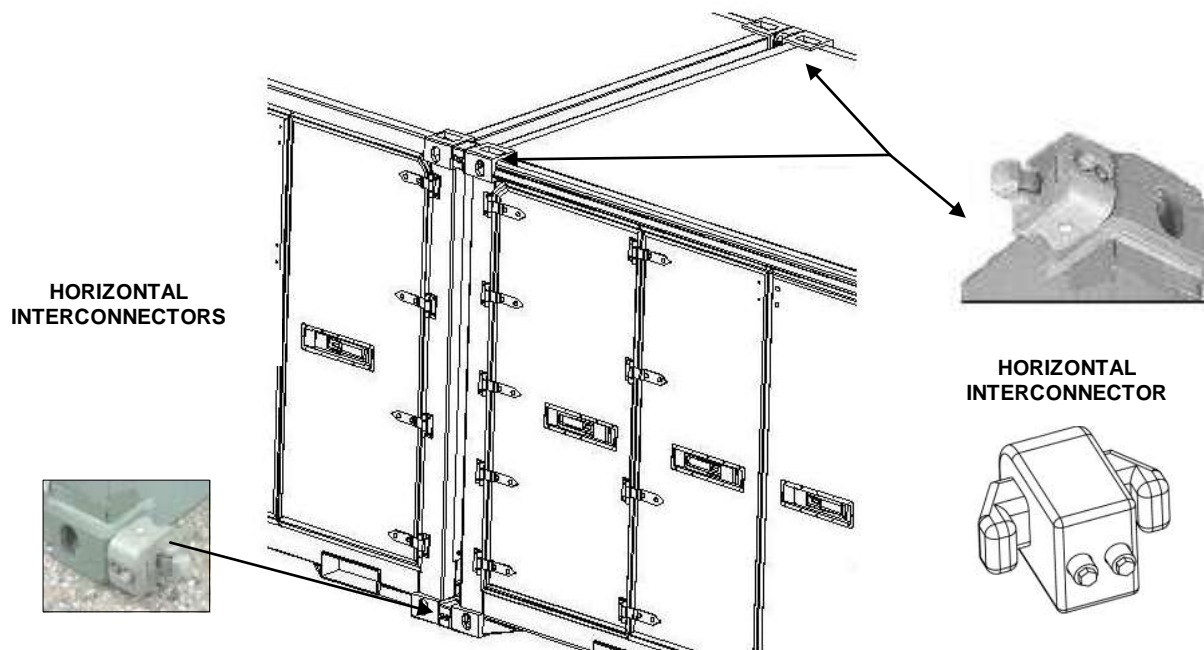

NOTE
NOT APPLICABLE FOR CARGO-6 CONTAINERS

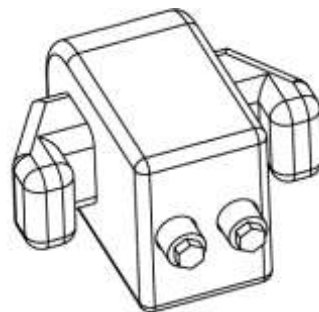

**9/16-INCH HEX HEAD LOCKING
ADJUSTMENT BOLTS**

0005 00-7

FPU-8-2/BOH-CARGO-12-1 CONTAINER CONECTION

1. Select only a firm level road surface to connect the containers.
2. Horizontal interconnectors should have both arms extended in the open position and the adjustment nuts positioned outboard.
3. Access the roof via the roof folding steps in the end of the FPU-8-2.

NOTE: Always position the FPU 8-2 with the folding steps on the end to access the roof.

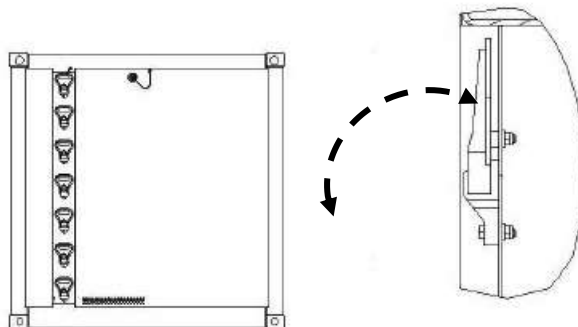
**WARNING**

Fall hazards exist when climbing onto, returning from, or working from the top of the container. When climbing on the FPU containers, always maintain three points of contact to the steps and roof access handle located on the containers. Never move, step, or walk backwards when working on top of the system. All movement should be in the forward direction. A fall can occur if the worker loses concentration and steps backwards off of the edge. Stand erect only if necessary and only away from the edge. Working from a kneeling position helps reduce the threat of a fall.

4. Insert the ear of the horizontal interconnector into the corner block opening on the FPU-8-2. While holding the horizontal interconnector in place, tighten the bolt in the interconnector body closest to the frame until seated firmly using a 9/16-inch hex socket, 2 ½"-inch long extension ½" square drive flex head wrench. The bolt will be recessed and flush with the connector housing when complete.

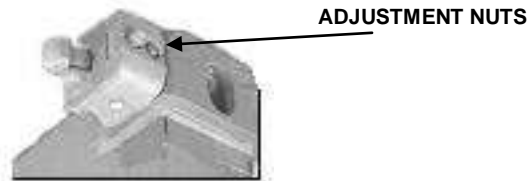

5. After the (2) upper horizontal interconnectors are secured in place climb down from the roof, via roof access system.
6. Insert two horizontal interconnectors into the lower ISO corner block openings in the FPU-8-2



WARNING



Make sure all container connectors are properly seated and locked secured. Failure to comply could cause serious injury.

WARNING



To prevent personnel injury, there should be no personnel on the roof before proceeding to next step.

CAUTION

Use lumber between the lift carriage and container to protect to end of the container from damage when pushing the container.

7. Using a forklift and ground guide position the FPU-8-2 next to the BOH-CARGO-12-1.
8. Ensure the ears of the horizontal Interconnectors are close to and aligned with the opening on the corner blocks on the BOH-CARGO-12-1. The better aligned of the ear to the corner block opening the easier the connecting process will be.
9. Using ground guide position the forklift at the end of the container and slide the forklift tines under the FPU-8-2. Leave about 24 inches of clearance between the forklift and FPU-8-2 container.
10. Turn off the forklift and set the emergency brake.
11. Lay the 6" x 6" x 5' section of wood blocking across the forklift tines to prevent the forklift from making direct contact with the FPU-8-2 container.



12. Using ground guides restart the forklift and slowly move the FPU-8-2 forward. As the FPU-8-2 approaches the horizontal interconnectors, maneuver the HME to ensure the ears on these connectors are fully engage into the opening of the ISO corner blocks on the FPU-8-2.

WARNING

Ground guides and the HME operators must maintain direct line of sight and insure that personnel are clear of the containers during this operation. If the forklift operator loses visual contact with either ground guide stop all operations, turn off the forklift and set the emergency brake. Resume only after reestablishing visual contact with both ground guides.

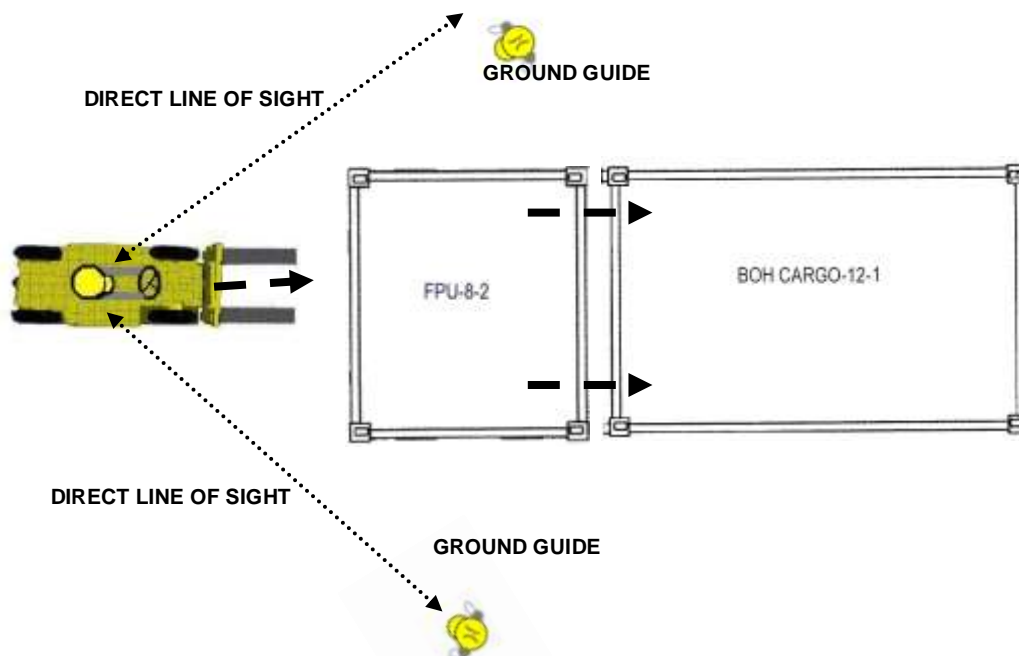

13. Turn the forklift off and set the emergency brake
14. Using the 9/16-inch socket, 2 1/2-inch long extension and ratchet tighten the adjuster bolt on the bottom horizontal interconnectors located closest to the FPU-8-2.
15. Restart the forklift. Using ground guide back the forklift away from the container until the forklift tines have cleared. The forklift will no longer be need.
16. Return to the roof via the roof access system located on the end of the FPU-8-2 to tighten the upper Horizontal interconnectors.

WARNING

Use extreme caution when connecting Field Pack-Up Unit (FPU) containers into a combination system. Forklift support is required.

CAUTION

Make sure all container connectors are properly seated and locked secure.

17. Continue to tighten both adjuster bolts on all four horizontal interconnectors until they are all tight and properly seated. Below identifies the proper torque order to follow. Torque Sequence:

- a. Top Right
- b. Bottom Left
- c. Top Left
- d. Bottom Right



18. Repeat tightening sequence several times until no more bolt movement is experienced. Ensure that all four horizontal interconnectors are sufficiently tightened prior to the next steps.

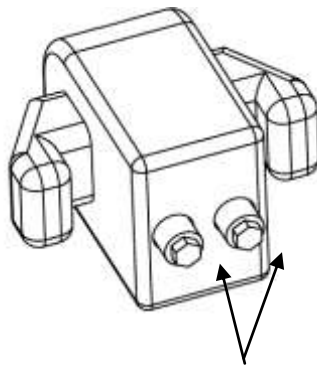

**9/16-INCH HEX HEAD LOCKING
ADJUSTMENT BOLTS**

WARNING

Use extreme caution when connecting Field Pack-Up Unit (FPU) containers into a combination system. Keep hands, finger, and feet clear of the container and components during this operation. Forklift support is required. Make sure all container connectors are properly seated and locked secure. Failure to comply could cause serious injury. Failure to follow proper connection procedures may result in damage to the equipment.

Standard forklift principles apply when working with or on the FPU container. When working with ground guides during the loading or unloading of a module, never move the module into the FPU container while the ground guide is between the fork, module, and the FPU container. Serious injury could occur if the ground guide is pinned between the forklift and the FPU container. Forklift operators must maintain visual contact with their ground guides at all times.

Always follow standard forklift procedures. Ground guides and the HME operators must insure that personnel are clear of the containers during this operation. A tilt hazard exists when forklift operators try to lift a partially loaded FPU container from the wrong side. Always lift a container with the heavier side closest to the forklift operator. This places the heavier part of the load back into the tines versus out on the tips. A tilt situation exists when the heaviest part of the load is out on the tips of the tines, on uneven ground, with forks fully extended, and while traveling. Operators should always keep loads low and close to the forklift carriage. Operators should never travel when the load is in the fork's extended position.

19. The locking adjustment bolts will be recessed and flush with the connector housing when completed.

20. Return to the ground via the roof access system on the end of the FPU-8-2.

WARNING

Fall hazards exist when climbing onto, returning from or working from the top of the container. Always maintain three points of contact to the ladder and FPU container when climbing onto the FPU container.

All BOH FPU cargo containers are marked with the following ISO marking. Its meaning is provided below:



WARNING



Overhead power lines and obstructions can cause serious injury or damage to property. Forklift operators, truck drivers and ground guides should always clear overhead when loading, unloading or accessing the roof of the containers.

WARNING



Ensure all container connectors are properly seated and locked. Additionally, ensure all internal material is secured through the use of drawer locking mechanisms, load constraint bars, cargo strap/netting, pallet lock rods, module locking devices (WP 0005 00 - 0006 00). Failure to comply could cause serious injury.

MOVING THE FPU USING MHE (FORKLIFT)

The FPU-8-2 and BOH-CARGO-12-1 containers are designed with forklift pockets located on their sides. When the two containers are connected together the two inside forklift pockets are used. The FPU-20-1 & 2 have 1 set of inside forklift pockets that are used to move it when empty and one set of outside forklift pockets to move it when loaded.

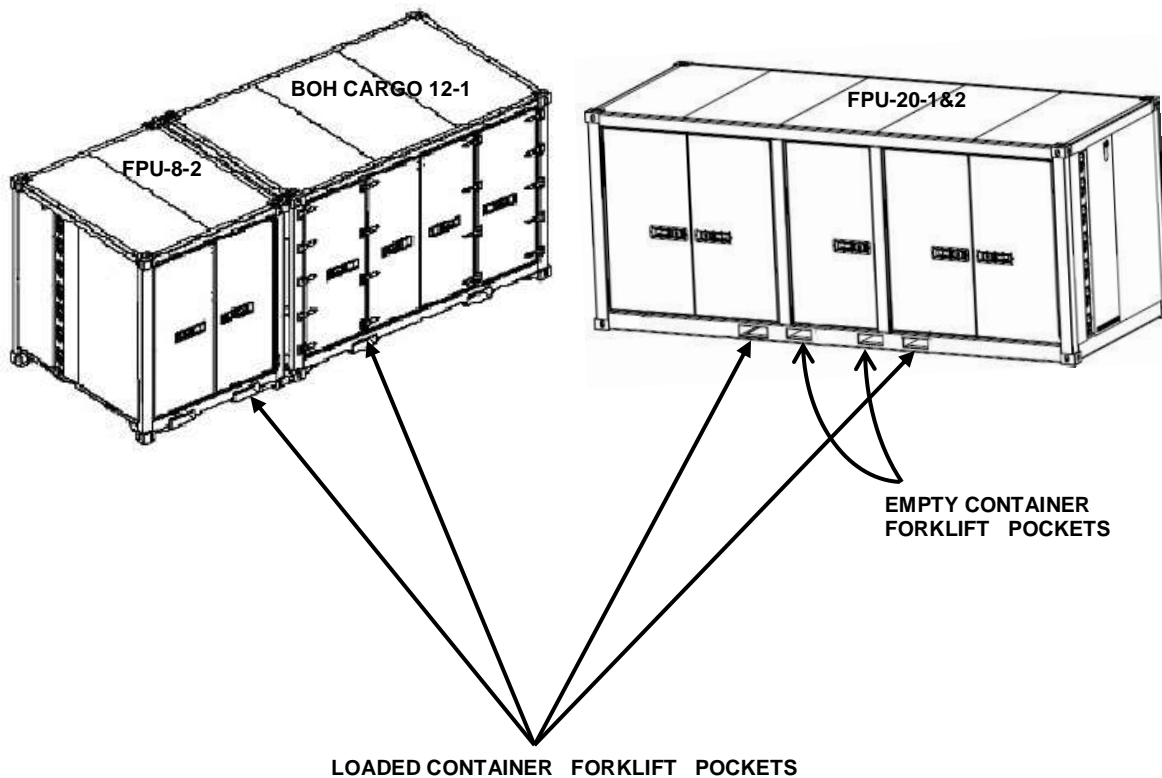

NOTE

The forklift pockets on the FPU-20-1 & FPU-20-2 are centered for greater load balance of the container. The FPU 8-2 and the each have their own forklift pockets. The four fork pockets on the FPU-20-1 & FPU-20-2 are provided to adjust HME position to maintain balance.

CAUTION

The center two forklift pockets must be used to maintain load balance when the FPU 8-2 and the BOH CARGO 12 are connected.

PLS SYSTEM

Loading and unloading via the PLS or LHS must be accomplished as indicated in PLS / LHS technical manuals. Loading and unloading onto and off of a M1076 Palletized Load-handling System Trailer (PLST) must be accomplished as indicated in the PLS trailer technical manual (TM9-2320-364-10).

CAUTION

Operators should always adjust driving speed to local conditions ensuring a safe operation based on local conditions. If a 6-inch washboard effect is encountered, it may be necessary to reduce speed to as low as 3 miles per hour to avoid damage to the FPU and its contents.

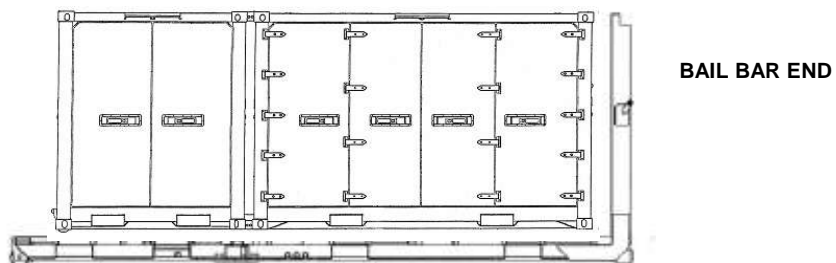
**M1075 PLS CURBSIDE****NOTE**

Consult the M1075 (TM-9-2320-364-10) for loading procedures and operation and securing devices. The FPU containers are positioned on the PLS so the ISO corner blocks receive the PLS lock-down devices to secure the containers.

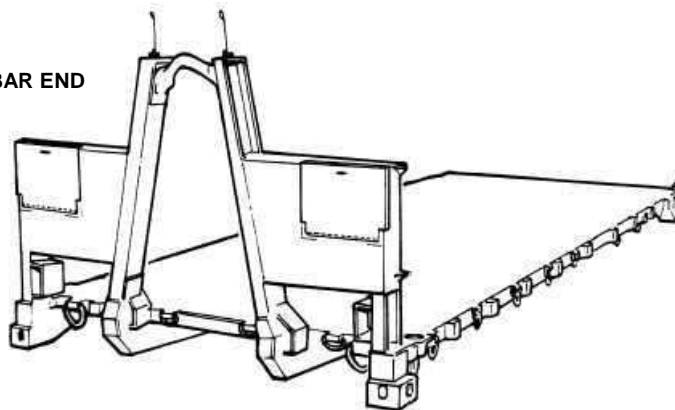
PLS BAIL BAR END

TRANSPORT USING THE BOH FPU TRANSPORT SYSTEM (FPU-TS)

The BOH FPU-TS trailer is a special designed trailer that accepts a variety of FPU container configurations, including the FPU-8-2/BOH-CARGO-12-1, the FPU-20-1, FPU-20-2, and a FPU-8-2/BOH-CARGO-6/FPU-8-2 combination. The trailer has integrated locking devices, and may require additional bridge locks and horizontal interconnectors to accommodate specific linked containers. Consult the FPU-TS trailer operators' manual for load position requirements and load option details.

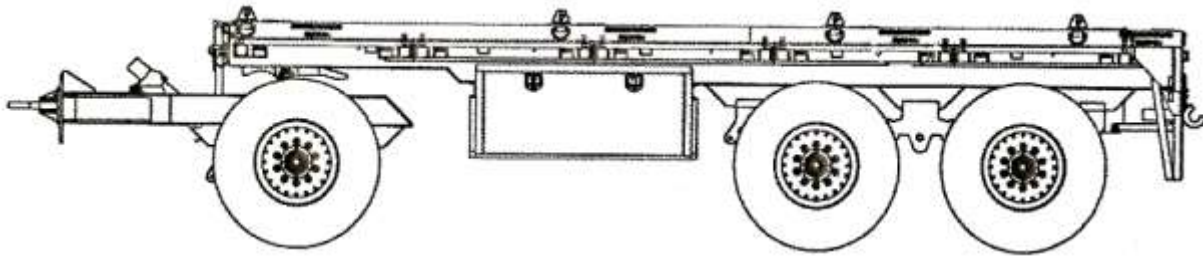

The FPU-TS trailer has pullout platforms that give access to the container contents without unloading the container.





The FPU-TS trailer maximum gross weight is 35,000 lbs.

NOTE

For detailed operation of the FPU-TS refer to the trailer manual.
For further detailed information regarding the FPU-TS trailer contact:

BOH ENVIRONMENTAL LLC
14520 Avion Parkway, Suite 220
Chantilly, Va. 20151
POC Jim Stokes (703) 449-6020
<http://www.bohenvironmental.com>

END OF WORK PACKAGE

**OPERATOR INSTRUCTIONS
FPU SYSTEMS OPERATION MANUAL
(INCLUDING REPAIR PARTS & OPTIONAL ACCESSORIES)**

**FOR
MODELS FPU-8-2, BOH-CARGO-12-1, BOH-CARGO-6 & FPU-20-1 & 2
OPERATION OF FPU CONTAINERS**

OPERATION OF FPU CONTAINER DOORS

This work package provides procedures associated with safe and efficient operation of the FPU and FPU components. Familiarity with these procedures will allow military units to derive maximum benefit from FPU modularity and the options for FPU configuration.

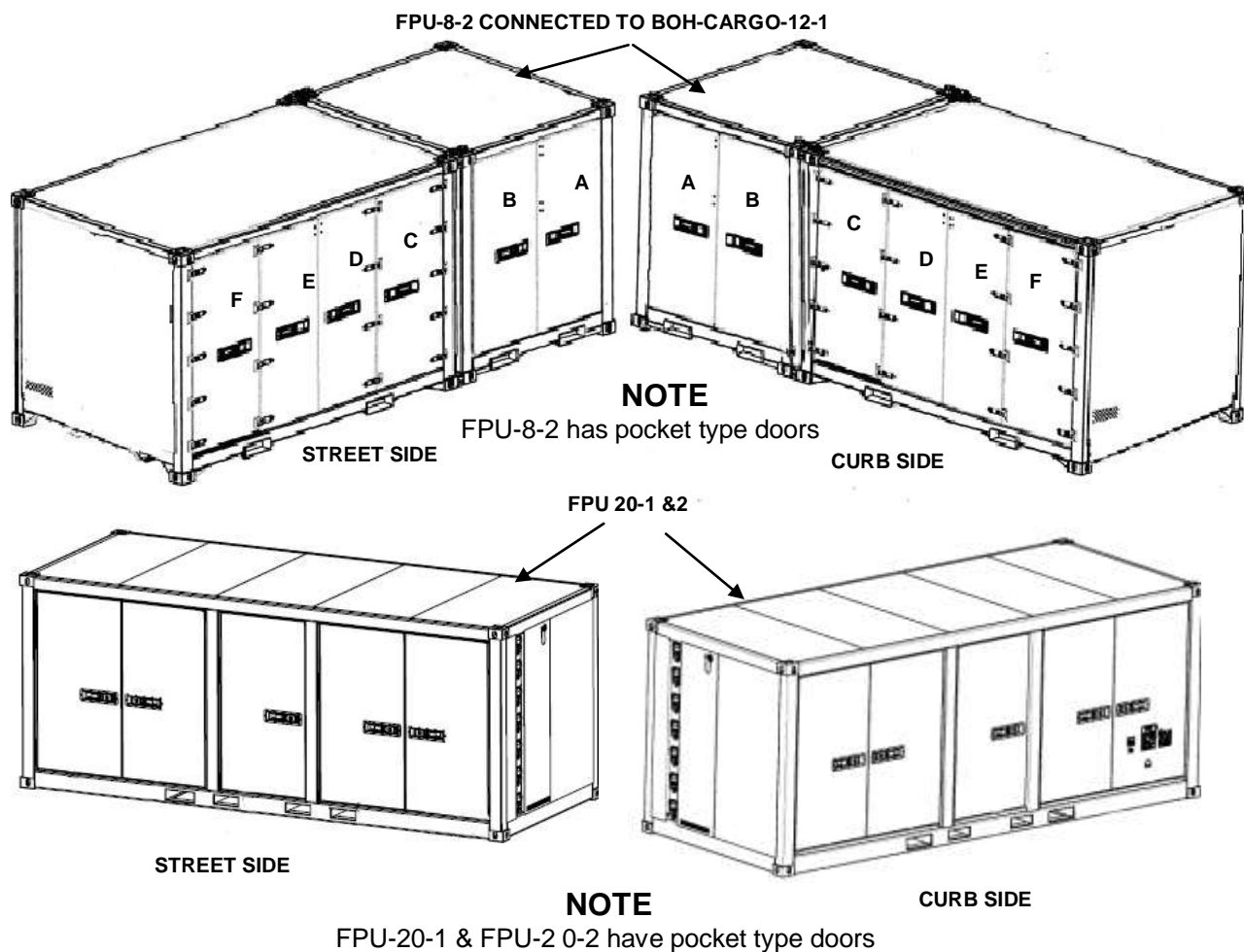

OPERATION OF FPU DOORS

Opening the Doors

NOTE

The FPU-20-1 FPU-20-2 and the FPU 8-2 doors are pocket type configuration and retract within the container. All of the following Warnings, Cautions and procedural steps apply to the FPU-8-2 BOH-CARGO-12-1, FPU-20-1 and FPU-20-2 when opening, closing and securing the doors.

WARNING



Use care when opening door while containers are on an incline, to maintain control consider the ground surface conditions for adequate traction, such as mud, snow, ice, sand and seek assistance from fellow soldiers to prevent strain or injury.

Pocket Type Doors

The doors on the FPU-20-1 FPU-20-2 and the FPU-8-2 have pocket type doors and are retracted within the container when in the full open position by means of top and bottom roller tracks (1).

CAUTION

The right pocket doors should always be the leading door when closing the doors to prevent damage to the seals. Care should be taken to clear any obstructing debris in the door guide (1) and door roller tracks (2) or door travel path that impedes the opening or closing of the door.

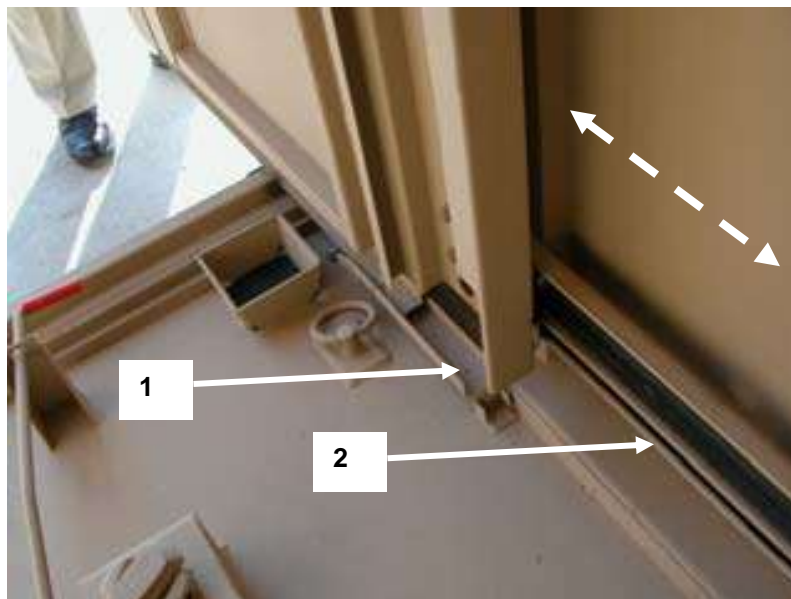

CAUTION

When closing the BOH-CARGO-12 center doors always allow the right hand door to lead slightly to mate the door seal edges and prevent damage to the seals.

CAUTION

The FPU containers will exceed the width requirement if a heavy security padlock is used to secure the exterior doors. Padlocks not exceeding one-inch shank length will allow the width requirements to be met. Padlocks may be taped to the exterior doors to ensure further measures will stay within the ISO envelope.

Opening FPU-8-2, FPU-20-1 & FPU-20-2 Doors

1. Using your right palm for left-hand doors and left palm for right hand doors, depress locking latch while using your free hand to prevent handle from springing outwards.

NOTE:

When opening the doors of the FPU-8-2 and the double doors of the FPU-20-1 & FPU-20-2 begin with the left doors first.

WARNING

The container door release grip has limited room allocated for hand space. This creates a pinch point at the handles when closing the door. Place the door handles in the closed position after opening the doors so they will fold against each other.

2. Rotate both handles to the full open position.
3. Pull door outward 90 degrees.

WARNING

Use care when opening door while containers are on an incline, to maintain control consider the ground surface conditions for adequate traction, such as mud, snow, ice, sand and seek assistance from fellow soldiers to prevent strain or injury.

- Depress handle until it is in its' closed and locked position to prevent the handle from obstructing closing of the door.

CAUTION

Door handles must be re-latched in their closed position to prevent equipment damage to handles as doors are pushed back into the open position.

- Push door inward until it makes contact with the doorstop located inside and in the middle of the container. The door should now be fully retracted to the inside of the container.
- Repeat this process for the right doors and the center doors of the FPU-20-1 and FPU-20-2.

Opening the BOH-CARGO-12-1 Container Doors

NOTE

The two center doors (Doors D and E) of the BOH-CARGO-12-1 must be opened first and simultaneously.

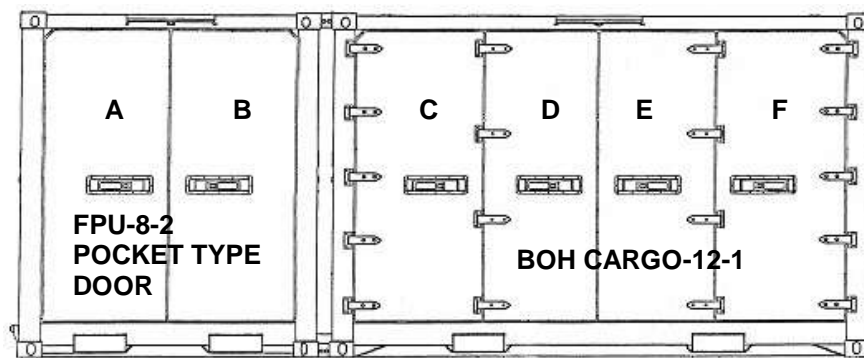

- Opening one door handle at a time, use your right palm for left-hand doors and left palm for right hand doors, depress locking latch while using your free hand to apply pressure on the handle to prevent it from springing outwards.

WARNING



The container door release grip has limited room allocated for hand space. This creates a pinch point at the handles when closing the door. Place the door handles in the closed position after opening the doors so they will fold against each other.

NOTE

Unlatch all four doors prior to attempting to open doors. Unlatching all door handles will assist in unseating doors.

- Rotate handles on all four doors to their full open position.

CAUTION

When doors are open, door handles must be latched in closed position to prevent equipment damage to handles as doors are folded back in the open position.

3. Grasp both the center door handles (D and E) and pull bi-fold doors simultaneously. Because containers are constructed with tubular steel and are subject to flexing when containers are sitting on an un-level surface, doors may be difficult to open. In this event you may require the assistance of other personnel to open the doors.
4. Grasp handle for doors C and F and pull outward until fully open.
5. Close door handles, fold doors and swing them away from the container.

Closing BOH-CARGO-12-1 Doors

FPU door seals consist of a double lip design in which the inter lip forms a tight seal against a fixed surface around the door opening while the outer seal over laps the door facing to provide a double sealing protection against the environment. Over lapping doors requires one door (left side) to have double seal lips while the adjacent door (right side) has a single seal lip (no outer seal lip). During the closing process, as the over lapping doors begin to mate, be sure that the door with no outer seal lip (right side) is ahead of the double seal lip door (left side).

CAUTION

Prior to beginning the door closing procedure, ensure that the container threshold is completely free of debris (dirt, sand, gravel, etc.). This will provide for proper sealing of the doors and prevent leaks.

WARNING

To prevent injury to personnel, caution should be exercised when releasing more than one door at a time during windy conditions.

1. Disconnect door restraint devices from doors (when equipped). Doors should be in perpendicular position for ease of restraint removal.
2. Hook restraints (when equipped) to the doors do not allow them to hang free.

- Unlatch door handles by depressing the locking latch and rotate handles to their full open position.

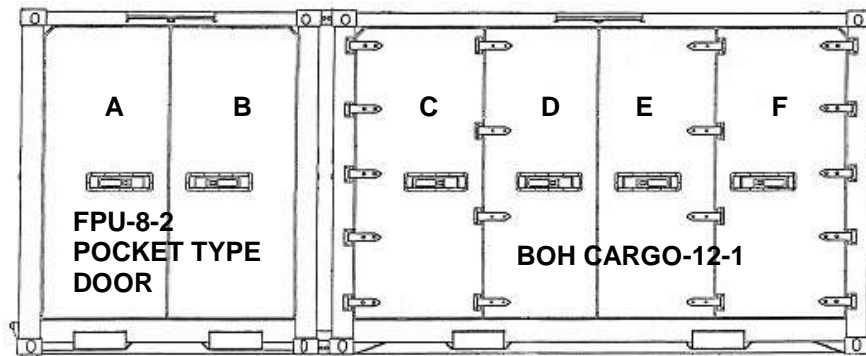

CAUTION

When closing process the FPU-8-2 pocket type doors the right door B should lead the left door A slightly so that the door seals mate properly and prevent damage.

- Close outer doors C and F first by swinging inward and pushing firmly until the door cams engage the door cam keepers inside the container. Close handle insuring the cams properly seat inside the upper and lower cam keepers.
- Close both doors D and E simultaneously aligning the single seal lip of the right door E to be slightly ahead of the double seal lip left door D. Close handle insuring the cams properly seat inside the upper and lower cam keepers.

Closing FPU-8-2, FPU-20-1 and FPU-20-2 Doors

- When closing double doors of the FPU-8-2, FPU-20-1 and FPU-20-2 begin with the right side doors. Grasp the door and pull outward until the door is completely clear of the inside of the container.
- Open the door handle by depressing the handle button and swinging the handle outward.
- Swing the right hand door around and push inward until the cams are aligned behind the cam keepers.
- Push handle inward insuring the cam keepers have positioned themselves behind the upper and lower cam keepers and the handle is in its locked position.
- Repeat these steps for the left hand double and center doors.

WARNING

Ensure lower receptacle is clean of debris before beginning this process.

OPERATING ADJUSTABLE DRAWERS WHEN CONFIGURED WITH PARTS STORAGE AIDS BOH-CARGO-12-1.**NOTE**

All of the following Warnings, Cautions and procedural steps apply to the BOH-CARGO-12-1 when removing, installing, adjusting and securing the drawers. Adjustable drawer slide ledges have been installed in the BOH-CARGO-12-1 when equipped with optional Parts Storage Aids. These slide ledge assemblies are attached to the vertical rack frame at two locations by four 1/4 inch carriage bolts at each point of attachment. Drawers are mounted to these ledges by four bolts on each ledge.

All drawers are full extension and are operationally secured by locking rod handles to prevent opening during transport or accidental closing during use. Drawers consist of fixed longitudinal dividers and moveable transversal dividers that allow adjustment on two-inch centers. Drawers are rated with a maximum capacity weight limit of 150 lbs per drawer.

CAUTION

Do not exceed maximum weight limit of 150lbs per drawer. Exceeding load limits may damage slide and drawer systems.

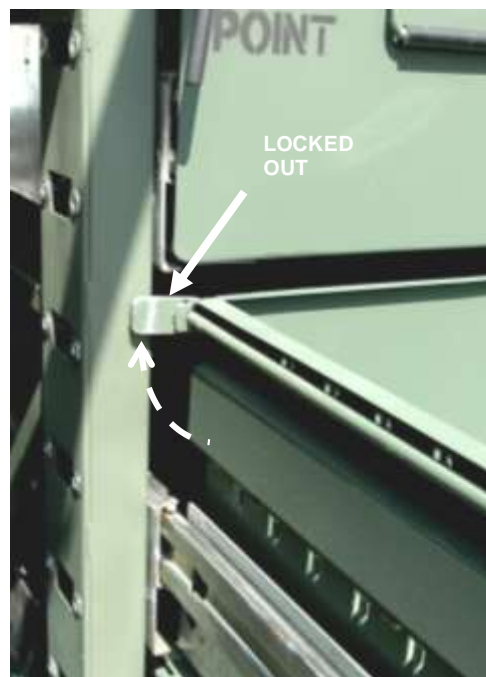

Opening and Closing Drawers (FPU parts only)

WARNING



Use care when opening drawers while containers are on an incline. Physical injury may occur. The container should be placed on as level a terrain as possible and periodically be checked for shift in its position from its level state.

WARNING



Do not use bottom drawers or pallets as step substitutes when trying to access ASL located on upper drawers and pallets. It is recommended that an optional 4-step stairway with handrail be used to access upper drawer and pallet material.



CAUTION

Never allow material to exceed the height of the drawer sides. Material exceeding drawer height will interfere with travel of that drawer and the drawer above.

Opening Drawers

Rotate the two locking mechanism handles upward toward the center of the drawer and hold in the open and horizontal position. Pull out until the locking handles can be released to lock the drawer in the open position. The drawer is in the open and locked position when the locking tab at the rear of the drawer has cleared the left and right stanchions.

NOTE:

Drawers will lock in both the closed and fully extended position.

Closing Drawers

Rotate the two locking mechanism handles upward toward the center of the drawer and hold in the open and horizontal position. Push the drawer in until the locking handles can be released to lock the drawer in the closed position.

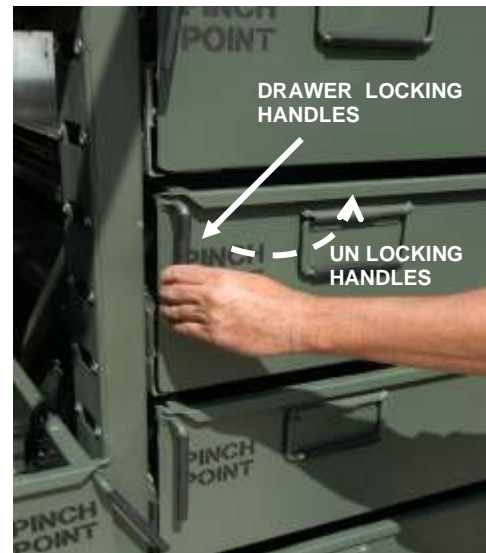
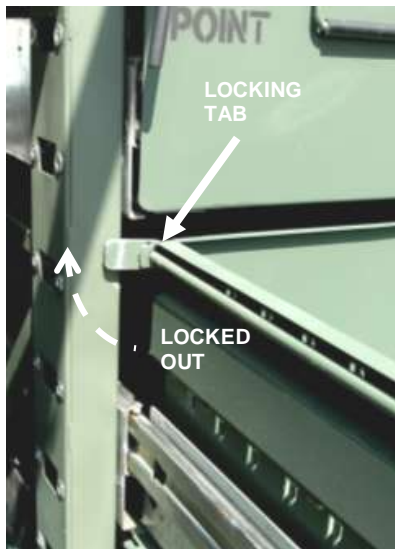

Moving/Adjusting Drawer Dividers

Drawers consist of fixed longitudinal dividers and moveable transversal dividers that allow adjustment on 2-inch centers from front to rear. To move a divider, grasp each side of the divider at the top and pull upward until free. Select the desired position and insert divider into slots on drawer. Be sure divider is inserted into slots directly across from each other. Twelve-inch drawers consist of multiple slots for maximum retention of divider. Ensure divider is engaged in all the slots at the chosen location and is seated completely to the drawer bottom surface.

Repositioning Drawers (BOH-CARGO-12-1 Parts only)

1. Fully extend and lock the drawer in open position.
2. Remove all stored material from drawer.
3. Remove eight ¼-inch screws located in the bottom of the drawer at either side.

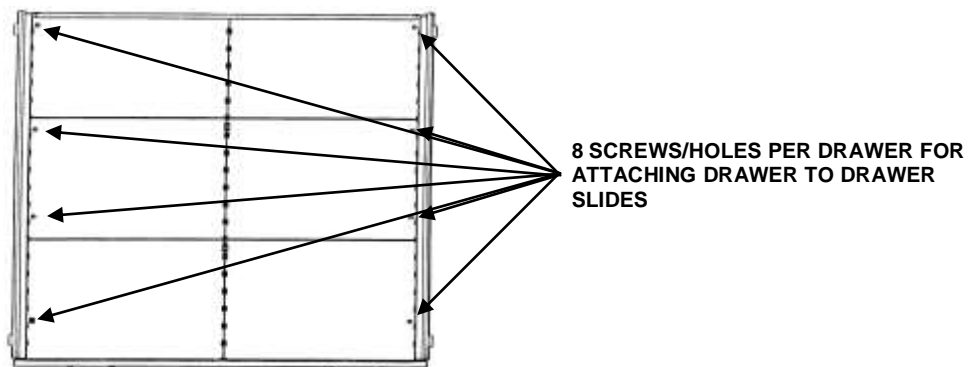

4. Lift drawer from slide ledges.

CAUTION

If a bolt is lost or damaged beyond use, obtain a replacement. Do not install with less than the proper number of bolts or equipment damage may occur.

5. Loosen but do not remove the four front and rear ¼-inch nuts on the carriage bolts using a ¼-inch socket with ratchet and extension.

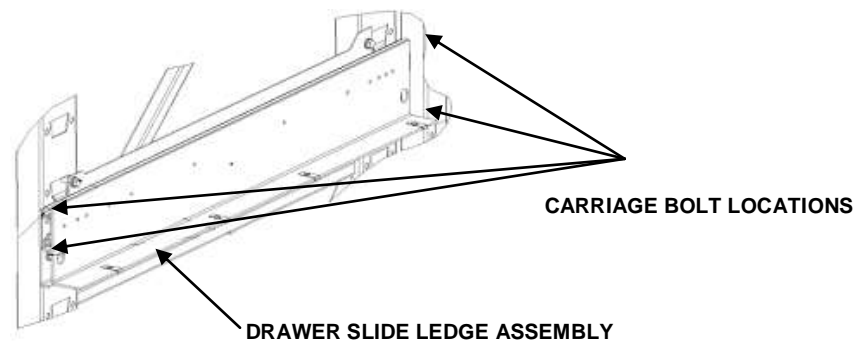

6. Slide ledges are retained on the vertical rack frame by two bayonet tabs protruding into the windows of the vertical rack frame. This requires the ledge to be loosened from the vertical rack frame. While one person securely holds the slide ledge, the second person applies an upward force by tapping the under side of the ledge at the attached point with a 2 X 4 soft wooden block or similar material.
7. Place the drawer slides ledges in their desired positions by inserting the bayonet tabs into the vertical rack frame windows and while aligning the four carriage bolts into their appropriate slots. Tap down on the ledge a 2 X 4 soft wooden block or similar material. Ensure the carriage bolts drop completely down in the slots.

NOTE

Drawers may be adjusted in 4-inch increments.

8. Tighten drawer slide ledge to rack frame by tightening the four ¼ -inch carriage bolt nuts bolts using a ¼ -inch socket with ratchet and extension.
9. Reposition the drawer on to the slide ledge careful to align mounting holes.
10. Install all eight bolts and lightly hand-tighten.
11. After hand tightening and prior to full tightening of the eight ¼-inch mounting screws, push drawer completely closed and pull back to its full-extended position to allow the drawer to seat into its proper location on the drawer slide ledge.
12. Being careful not to over tighten, secure the eight ¼-inch mounting screws.

OPERATING FPU PALLETS (BULK STORAGE AIDS)

Each pallet position in the pallet rack system consists of a pallet and left and right load centering adjustable pallet mounting ledges. Ledge assemblies are attached to the vertical rack frame at two locations by ten ¼ -inch carriage bolts and nuts. When pallet is inserted on pallet ledges, they are secured by rear cam locks and held in front by two adjustable lock rods that seat the pallet into position when tightened. All pallets are provided with nets or ratchet straps to secure material. Pallets are rated with a maximum capacity weight limit of 1,000 lbs.

CAUTION

Do not exceed maximum weight limit of 1,000 lbs per pallet. Exceeding load limits may damage pallets and pallet ledges.

CAUTION

Ensure the lock rods have been completely retracted prior to removing or inserting the pallets.

WARNING



Never work underneath loaded pallets. Failure to comply could cause serious injury or death.

FRONT LOCK

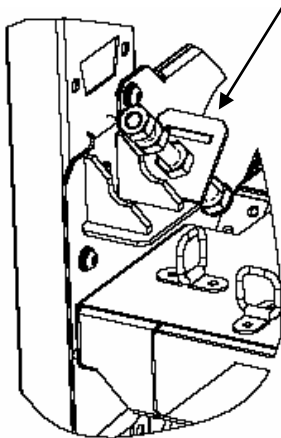

REAR LOCK

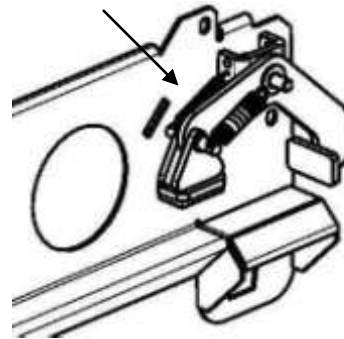

Inserting Pallets

The following process will require a forklift operator and a ground guide.

1. Adjust forklift tines to match fork pockets of pallet to be installed.
2. Pick up pallet with forklift.

NOTE

Pallets are designed with a forklift tine stop to ensure proper distance is maintained between the forklift bridge and the FPU container. It also assists in inserting the pallet to the rear locked position.

- Using the ground guide align pallet to the pallet ledge opening.

CAUTION

Ensure the lock rods have been completely retracted prior to removing or inserting the pallets.

- Once approximately 12-inches into the pallet ledge lower the pallet and allow it to slide along the pallet ledge into the lock position.
- Retract forklift.
- Tighten the lock rods evenly using 7/8-inch deep well socket and V2-inch drive flex head wrench to secure the front of the pallets. Continue alternating from one lock rod to the other until the pallet is properly seat under the locking cam located and the rear of the pallet.

NOTE

Alternate tightening sequence left to right to ensure proper alignment of pallet on pallet ledges.

- Tighten Jamb nut using 7/8-inch combination wrench to hold lock rod in the closed position.

Removing Pallets

- Loosen jam nuts using 7/8-inch combination wrench.

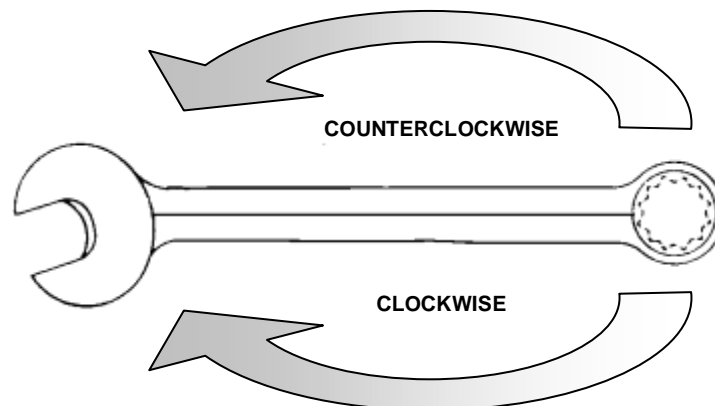
**NOTE**

All hardware, bolts, jam nuts, and screws are loosened with a counter clockwise rotation. All hardware, bolts, jam nuts, and screws are tightened with a clockwise rotation.

- Completely retract lock rods using 7/8-inch deep well socket and V2-inch drive flex head wrench. Turn lock roads counterclockwise fully until retracted. The rod will bottom out when fully retracted.
- Adjust forklift tines to match fork pockets of pallet to be removed.

4. Using the Ground Guide insert tines into pallet until contact with pallet stops is made.
5. Using one of the 2-inch ratchet straps provided, attach one hook to a left front pallet D-ring.
6. Feed strap through the forklift bridge to opposite side and attach to a right front pallet D-ring.
7. Tighten ratchet strap to remove any slack.
8. Raise the forks approximately 1-inch.
9. Back out slowly approximately 12-inches to allow pallet to clear rear cam lock.
10. Tilt forks back to obtain approximately 1-inch of clearance between the pallet and pallet ledge.
11. Continue backing out until clear. Once clear of container position pallet to desired location and lower to the ground.
12. Disconnect ratchet straps from pallet D-rings and remove from the Forklift Bridge.

Adjusting Pallet Position

1. Remove the pallet to be relocated and any pallets located above prior to beginning the following steps (Refer to inserting/removing pallet procedures).
2. Remove front and rear pallet ledge stabilizer by turning attaching bolts counterclockwise on each side of the stabilizer using 3/16-inch hex driver socket and 3/8-inch ratchet with extension.

NOTE

The operator must crawl into the container to remove the rear Allen bolts.

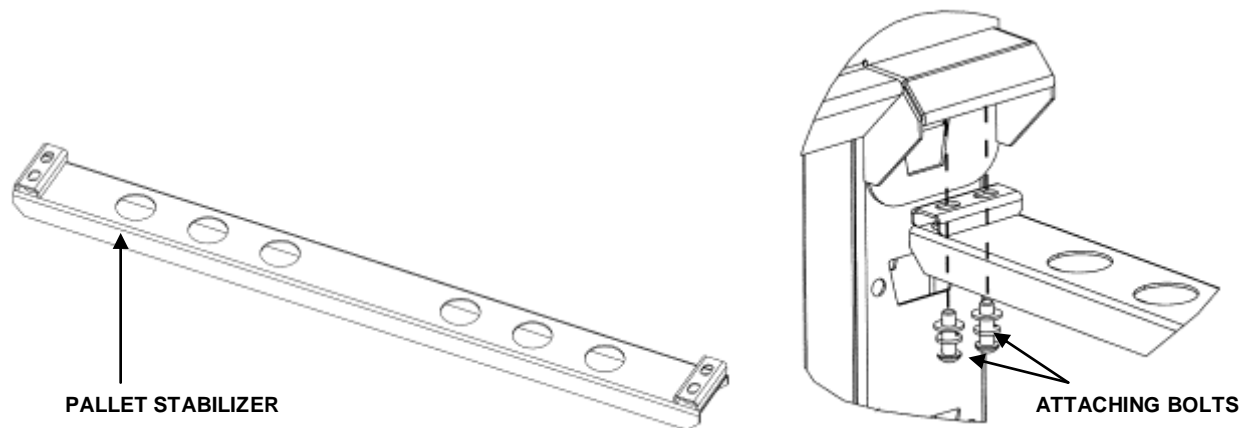

3. Loosen but do not remove the ten carriage bolt nuts using 1/4 -inch socket and ratchet with extension from the two pallet ledges on the vertical rack frame.

CAUTION

If a bolt is lost or damaged beyond use, obtain a replacement. Do not install with less than the proper number of bolts or damage to equipment may occur.

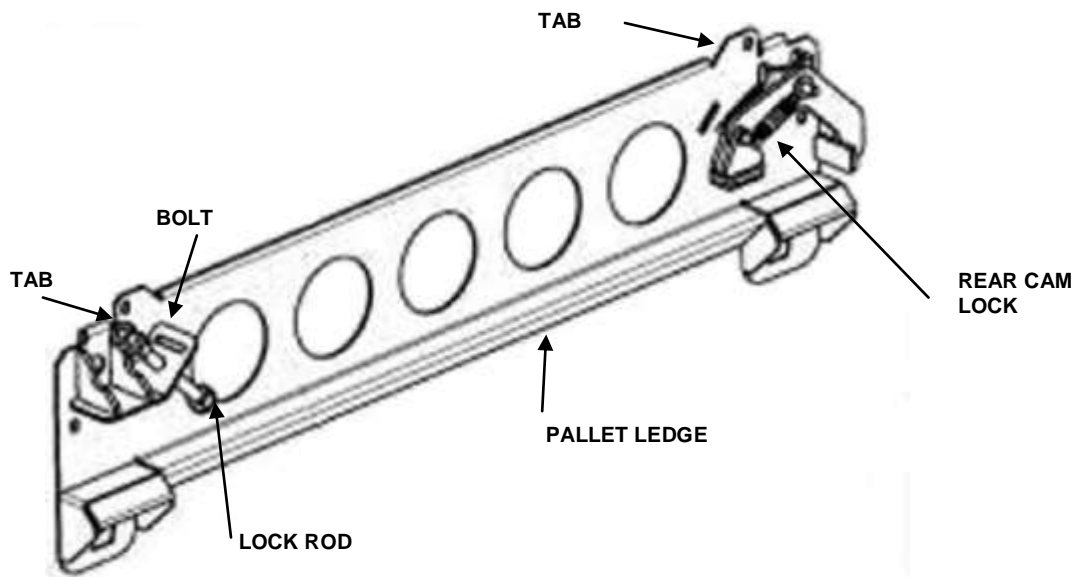

4. Pallet ledges are retained on the vertical rack frame by ten ¼-inch carriage bolts and four bayonet tabs protruding into the windows of the vertical rack frame. This requires the ledge to be loosened from the vertical rack frame. While one person securely holds the pallet ledge, the second person applies an upward force by tapping the under side of the ledge at the attached point with a 2 X 4 soft wooden block or similar material.
5. Place the drawer slides ledges in their desired positions by inserting the bayonet tabs into the vertical rack frame windows and while aligning the ten carriage bolts into their appropriate slots. Ensure that pallet ledges are at same height in the vertical rack frame. Ensure all bayonet tabs have engaged the vertical rack frame windows before tapping into place. Tap down on the ledge with a 2 X 4 soft wooden block or similar material. Ensure the carriage bolts drop completely down in the slots.

NOTE

Pallets may be adjusted in 4-inch increments

6. Tighten all ¼-inch carriage bolts.
7. Reinstall rear pallet ledge stabilizer, four Allen Bolts using 3/16-inch hex driver socket and 3/8-inch ratchet with extension at the two positions of each pallet ledge. Four bolts located at each vertical rack frame.
8. Reinstall front pallet ledge stabilizer four Allen Bolts using 3/16-inch hex driver socket and 3/8-inch ratchet with extension at the two positions of each pallet ledge. Four bolts located at each vertical rack frame.
9. Reinstall pallet (see installing pallet page 0006 -12).

SECURING FPU CARGO USING NETS (2-foot Drawers and HAZMAT Pallets Only)

FPU Cargo netting is attached to HAZMAT pallets and the tops of 2-inch parts drawers and then tightened around the stowed material by means of adjustable straps with parachute clips.

1. Place material to be secured in the 2-inch drawer or HAZMAT pallet.
2. Arrange net to ensure male and female parachute clips are aligned.
3. Attach the male ends of the parachute clips located on nets to the female clips located on the pallet.
4. Pull loose ends of the straps to remove slack.
5. To remove, detach parachute clips.

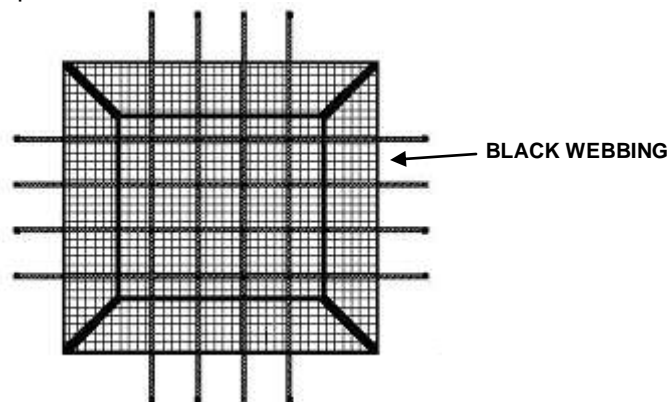

SECURING FPU CARGO USING FLOOR NETS (When configured with bulk/pallet storage aids)

WARNING



Some HAZMATs may react negatively with other HAZMATs. The MSDS for each type of hazardous material to be shipped must be referenced prior to shipment. All recommend safety procedures must be followed. Be sure to use the appropriate absorbent material inside the containers to absorb spills. All HAZMATs must be double wrapped prior to shipment in lined HAZMAT storage pallets. Failure to do so may result in damage to pallets, FPU cargo, and hardware and/or injury to personnel.

FPU floor cargo nets are designed to secure cargo directly to the floor of the BOH-CARGO-12-1 containers configured with bulk storage aids. These floor nets consist of a net with four safety snaps positioned to fit into the recessed rings located at the bottom of the vertical rack frames and an adjustable cinch rope that runs along the outer edge of the net.

There are two sizes of floor cargo nets:

- Four medium (used in BOH-CARGO-12-1 Bulk containers)
- Two small (used in BOH-CARGO-12-1 Bulk containers)

1. Remove pallets directly above the position that the cargo is to be secured.
2. Insert load to be stored and secured.
3. Align net and attach the two safety snaps to the two rear rings of the vertical rack frame.
4. Feed the net over and around the load.
5. Attach the remaining two safety snaps to the two front rings of the vertical rack frame.
6. Pull cinch rope tightly to secure load in place.

SECURING FPU CARGO USING RATCHET STRAPS

FPU pallets are designed with a series of D-rings around their edges. D-rings have a combination load limitation of 1,000 lb per pallet. Pallets (except HAZMAT Pallets) are provided with four 2-inch ratchet straps that utilize a tension ratchet and snap hook ends to secure. These straps hook directly on to the D-rings. Proper position of these straps depends on size and shape of the material stored on the pallet.

Ratchet Strap

1. Extend the ratchet strap and fasten one snap hook end to one of the pad eyes on the edge of the pallet and extend the strap over the material to be secured until you can connect the other snap hook end to another pad eye on the opposite side of the pallet.
2. Grasp the loose end of the blue strap and take-up the slack in the drum and strap until the strap has firm contact with the material.
3. Use the ratchet handle to tighten and add tension to secure the material.
4. To remove the straps, grasp the tension release bar and pull toward the handle.

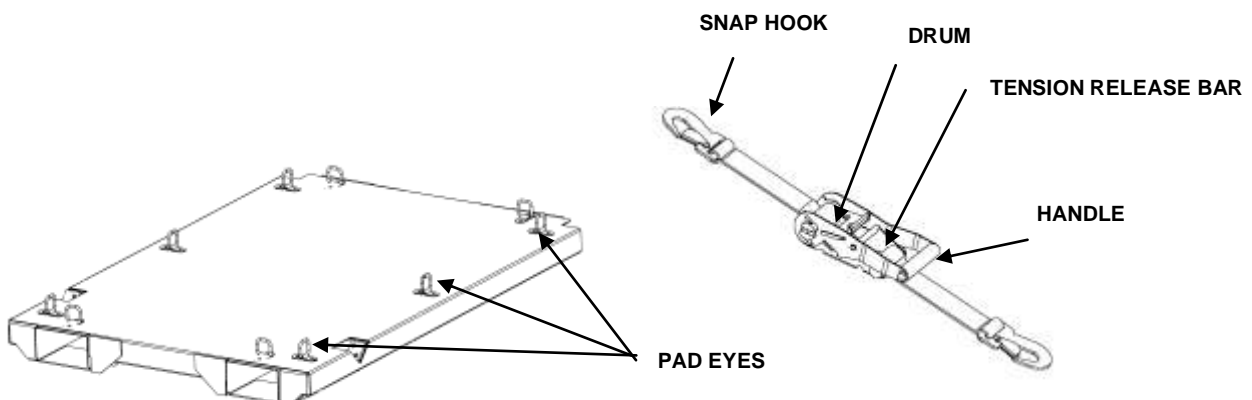

FLOOR TIE-DOWN RINGS

Floor Tie-Down Rings are used to secure large material to the floor of the container in place of the pallet rack stanchions with ratchet straps and have a load limitation of 5,000 lb.

1. Remove the Pallet Rack Stanchions top and bottom.
2. Replace with the Tie-Down Rings to the desired location on the floor.

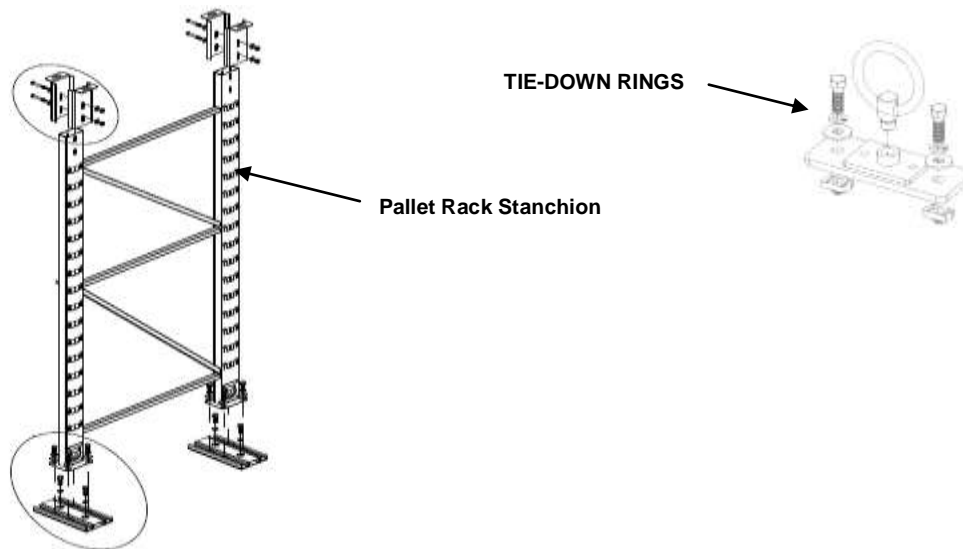

END OF WORK PACKAGE

This page was left intentionally blank

**OPERATOR INSTRUCTIONS
FPU SYSTEMS OPERATION MANUAL
(INCLUDING REPAIR PARTS & OPTIONAL ACCESSORIES)**

**FOR
MODELS FPU-8-2, BOH-CARGO-12-1, BOH-CARGO-6 & FPU-20-1 & 2**

LOADING/UNLOADING FPU MODULES

LOADING/ UNLOADING FPU MODULES (FPU-8-2 and the FPU-20-1 & 2 CONTAINERS ONLY)

The FPU Module System consists of a variety of standard and specialized storage/shipping modules. FPU modules are designed to be easily inserted and removed from the FPU-8-2 and FPU-20-1 & 2 series containers. Modules consist of four tapered feet and a female receiver located on the bottom that allows them to be mounted directly to the cradle positions on the floor of the container. Modules are retained in place using twist locks located in the center of the cradle arrangements. Modules are locked to the floor by pulling out or pushing in on the module-locking arm. FPU cradle arrangement provides four module storage positions in FPU-8-2 containers and ten positions in FPU-20-1 & 2 series containers.

Removing FPU Modules

1. Be sure modules padlock security bar is pinned in place.



2. There is a pad lock hasp provided with each padlock security bar.

3. Pull the red module-locking arm handle fully out to its open position.



4. Adjust forklift tines to fit forklift pockets on the FPU module.



5. With the assistance of a ground guide, insert tines into module.

NOTE

Be sure to enter the forklift pockets with tines above the red handle and allow approximately 18-inches between the forklift-bridge and module to prevent damage to the forklift or container.

6. Lift module directly upward maintaining a level position to a height just above the module receptacles on the floor adapter plate.

7. Using ground guide, slowly back out paying close attention to the guide and the upper clearance between the top of the module and container door cam keeper that protrudes downward from the top of the container frame. The module may have to be raised or lowered during this process if the tilt is too far forward or backwards.



8. Continue backing until completely clear of the container.
9. Transport to desired drop area and slowly lower until the module is resting fully on the ground.
10. Slowly back away until completely clear of the module.

Inserting FPU Modules

1. Be sure the padlock security bar is pinned in place.
2. Be sure red handle on the module-locking arm located on the floor adapter plate is pulled fully out to its open position.
3. Adjust forklift tines to fit forklift pockets on the FPU module.
4. With the assistance of a ground guide, insert tines into module. Stop with about 12-inches between the FPU module and the forklift bridge. This will allow for the clearance needed between the forklift bridge and the container frame when loading the module to prevent the bridge from making contact with the container frame.
5. Using ground guide, lift module and position feet directly above the four female receptacles located on the floor adapter plate at the desired module storage position.
6. Lower the module until it settles into its position (shifting the tines left/right as necessary to align properly).

7. Slowly back away from the module until the tines have completely cleared.
8. Push the module-locking arm in completely.

CAUTION

Verify that the module is properly seated and the red handle on the module-locking arm is pushed completely to its closed and locked position.



END OF WORK PACKAGE

**OPERATOR INSTRUCTIONS
FPU SYSTEMS OPERATION MANUAL
(INCLUDING REPAIR PARTS & OPTIONAL ACCESSORIES)**

**FOR
MODELS FPU-8-2, BOH-CARGO-6 & FPU-20-1 & FPU-20- 2**

OPERATION OF BOH-6 BULK CARGO CONTAINER

BOH-CARGO-6 BULK CONTAINER.

NOTE

The BOH FPU Module system does not apply to the BOH-6 BULK container.

The BOH-Cargo-6 (or Boh-6) is a general-purpose side load bulk cargo container with a single door. Door is equipped with exterior hinges and recessed cam type locking handle and comes with adjustable sectional shelves. The BOH-Cargo-6 measures 96"W x 72"L x 92"H with ISO corner blocks. It has a maximum capacity of 10,000 lbs and it can be fitted with additional shelves as required. It is designed as a stand-alone utility container or to fit between two FPU-8 series containers to completely fill the 20 ft. ISO envelope.



The BOH-CARGO-6 is provided with four shelf panels that are secured with wing nut, a bolt and shelf retaining clips to any of the three positions angle iron side brackets.

The shelves in the BOH-CARGO-6 rest on angle iron welded to the structure and are secured by 4 wing-nuts, securing clips, and tab clips at the back of the shelf that fits a cut-out.



WARNING



Ensure that the container floor area is clean of debris and oil or grease and that all material has been removed from the shelves prior to moving any shelf.

NOTE

Additional shelf panels may be acquired from:

BOH ENVIRONMENTAL LLC
14520 Avion Parkway, Suite 220
Chantilly, Va. 20151
POC Jim Stokes (703) 449-6020
<http://www.bohenvironmental.com>

CONNECTING FPU-8-2/BOH-CARGO-6/FPU-8-2 CONTAINERS ON A PLS FLAT-RACK**CAUTION**

Loading and unloading onto and off of a M1076 Palletized Load-handling System Trailer (PLST) must be accomplished as indicated in the PLS trailer technical manual (TM9-2320-364-10).

Bridge lock connectors are used in conjunction with ISO PLS mounted interconnectors for loading and transportation. Bridge Locks must be removed for maritime shipping to meet ISO certification standards.

NOTE

BOH FPU-8-2/BOH-CARGO-6/FPU-8-2 containers are connected using, four bridge lock connectors on the top of the ISO blocks. No horizontal interconnectors are required.

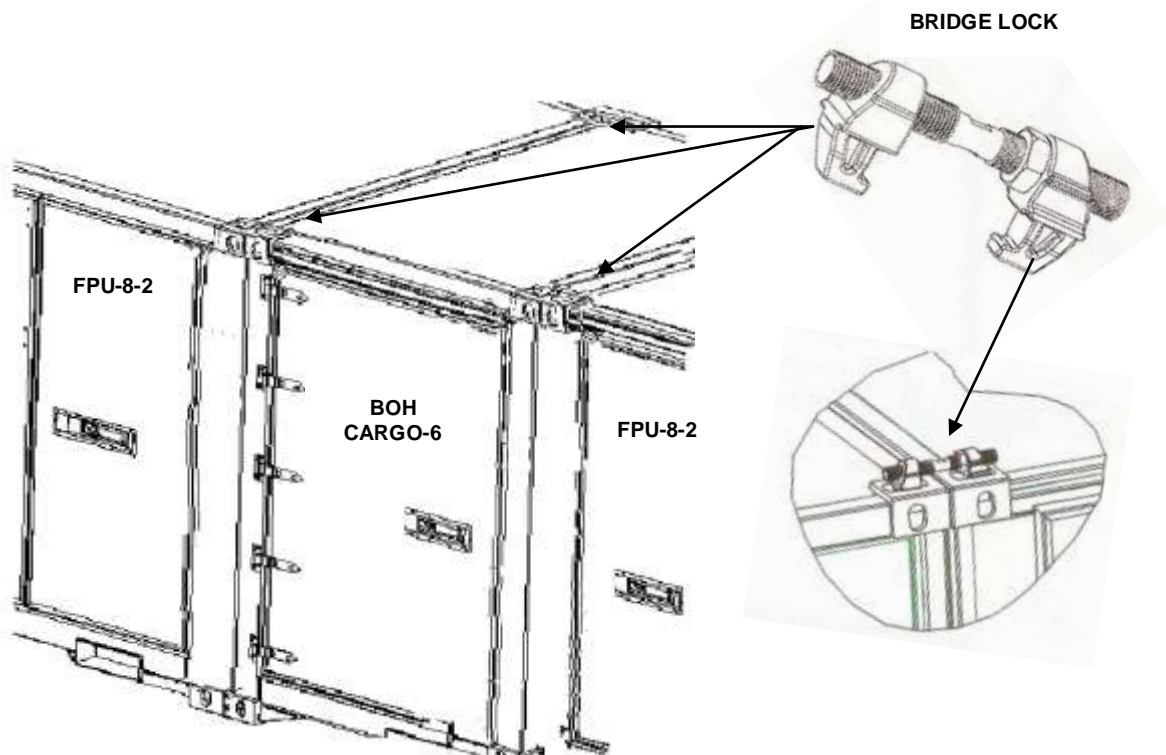

POSITIONING THE FPU 8/6/8 CONTAINERS ON THE PLS FLAT-RACK

WARNING



Ground guides and the HME operators must maintain direct line of sight and insure that personnel are clear of the containers during this operation.

NOTE

THE FOLLOWING SAFETY GROUND GUIDE INSTRUCTIONS APPLY TO THE FPU-8-2/BOH-CARGO-6/FPU8-2 CONNECTION PROCEDURE.

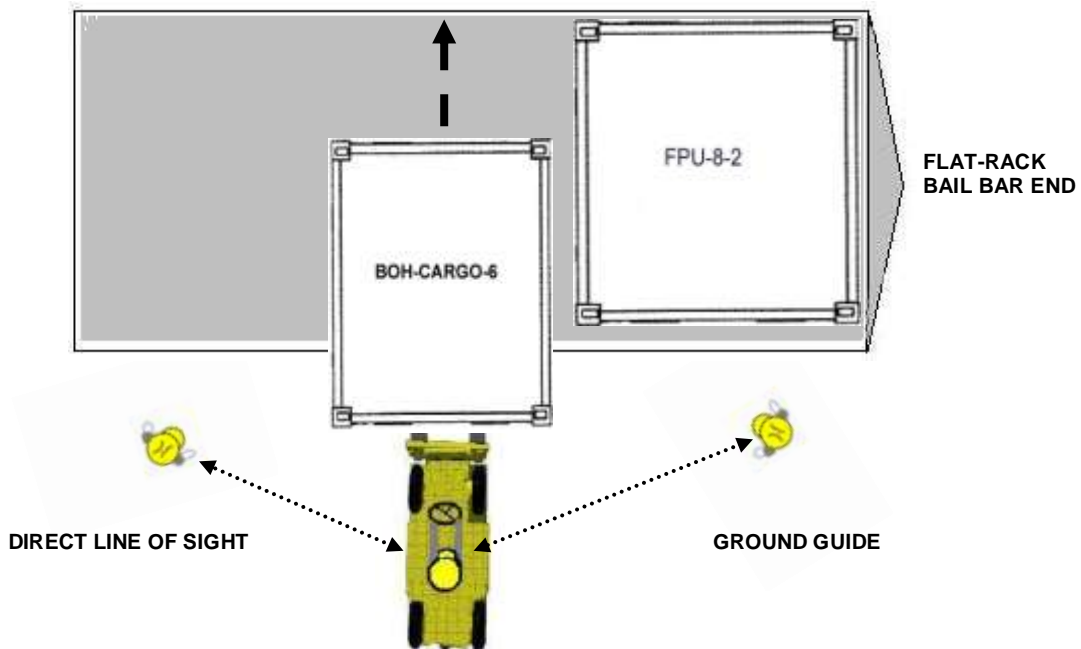

WARNING



Use extreme caution when connecting individual containers into a combination system. Two Ground Guides and forklift operator is required. Ground guides and the forklift

operators must insure that personnel are clear of the containers and maintain visual contact at all times during this operation.

1. Place the FPU-8-2 on the bail bar end of the PLS Flat-rack, align bottom two corner blocks on to the two PLS trailer twist locks.
2. Secure to trailer using the PLS twist lock devices.
3. Place the BOH-CARGO-6 inline with the FPU-8-2s and align the ISO blocks.
4. Place the second FPU-8-2 on the end of the PLS Flat-rack align bottom two corner blocks on to the two PLS trailer twist locks.
5. Secure to trailer using the PLS twist lock devices.

WARNING



Fall hazards exist when climbing onto, returning from, or working from the top of the container. When climbing on the FPU containers, always maintain three points of contact to the steps and roof access handle located on the containers. Never move, step, or walk backwards when working on top of the system. All movement should be in the forward direction. A fall can occur if the worker loses concentration and steps backwards off of the edge. Stand erect only if necessary and only away from the edge. Working from a kneeling position helps reduce the threat of a fall. Seek assistance when placing four bridge locks on the roof.

NOTE

Always position the FPU 8-2 so the folding steps are on the end to gain access the roof.

6. Place the four bridge locks, in each FPU-8-2 and BOH-CARGO-6 on the roof; access the roof via the folding steps system in the end of the FPU-8-2.

OPERATION and INSTALLATION OF BRIDGE LOCKS

NOTE

Bridge Locks are only required on the FPU-8-2/BOH-CARGO-6/FPU-2 connection during loading on the PLS Flat-rack. They eliminate the need for chain tie-downs.

Bridge Locks are connecting devices that utilize the top openings in the ISO corner blocks. This is an enhancement to the connection and securing of the three containers. Bridge locks should be installed whenever the FPU is to be transported on the PLS Trailer, container transport trailer, flat bed trailer, etc. Bridge locks must be removed before any movement of the containers and before turning over to maritime shipping personnel.

WARNING

Never attempt to pickup or move the FPU-8-2/BOH-CARGO-6/FPU-8-2 connected containers as units that have been secured with bridge locks. Damage and or injury to personnel will occur. The containers must be disconnected and moved individually with proper HME.

There are several versions of bridge locks/restraint locks but the most common Bridge Lock has a 2 1/8" jam nut and one 1-inch flat adjuster nut. The nut in the center is the adjuster flat nut and opens/closes the locks. The other is the jam nut and secures the locks in position after the adjuster nut has been tightened.

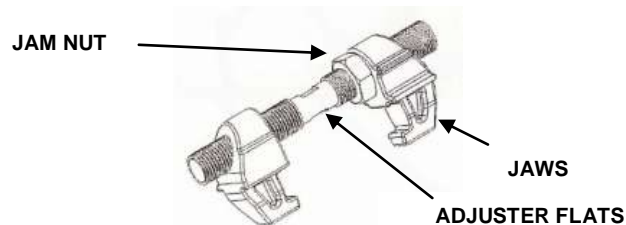
**WARNING**

Fall hazards exist when climbing onto, returning from or working from the top of the container. Always maintain three points of contact to the ladder and FPU container when climbing onto the FPU container. Never move, step, or walk backwards when working on top of the system. All movement should be in the forward direction. A fall can occur if you lose concentration and step backwards off of the edge. Stand erect only if necessary and only away from the edge. Working from a kneeling position helps reduce the threat of a fall.

1. Access the roof via the roof access system located on the FPU-8-2 to install the bridge locks.

2. In a kneeling position, orient bridge lock so that jaws turned towards the installer and jam nut is to the installer's right. Positioning the jam nut to the installer's right will ensure that the installer is pulling when tightening the adjuster and jam nuts.

WARNING

Always orient the jam nut to the installer's right to ensure that operator is always pulling towards him in a safe manner. Improper orientation may result in installer falling from the container roof causing serious injury.

3. Turn the jam nut counterclockwise so that it is positioned close to the adjuster nut.

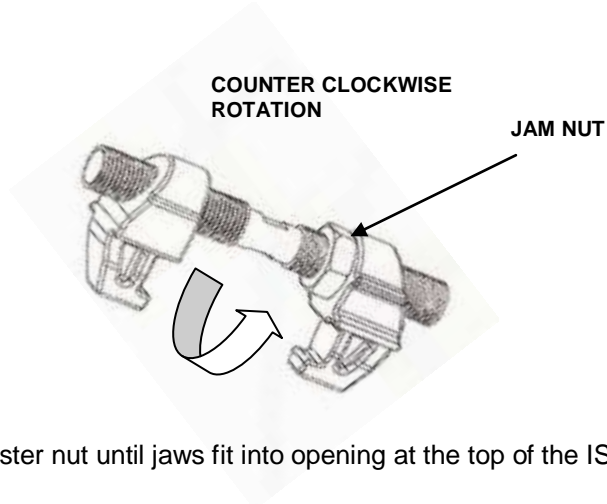

4. Expand/retract adjuster nut until jaws fit into opening at the top of the ISO connector.
5. Place jaws into corner block openings.
6. Tighten jaws using the 21/8" open end wrench by turning the 1-inch flat adjuster nut as tight as possible towards the installer.
7. Turn jam nut towards the closest jaw and tighten counterclockwise firmly.
8. Repeat procedure for all four bridge locks on the roof of the containers.
9. Return to the ground via the roof access system on the end of the FPU-8-2.

WARNING



Fall hazards exist when climbing onto, returning from or working from the top of the container. Always maintain three points of contact to the ladder and FPU container when climbing onto the FPU container.

All BOH FPU cargo containers are marked with the following ISO marking. Its meaning is provided below:

WARNING



Overhead power lines and obstructions can cause serious injury or damage to property. Forklift operators, truck drivers and ground guides should always clear overhead when loading, unloading or accessing the roof of the containers.

END OF WORK PACKAGE

**OPERATOR INSTRUCTIONS
FPU SYSTEMS OPERATION MANUAL
(INCLUDING REPAIR PARTS & OPTIONAL ACCESSORIES)**

**FOR
MODELS FPU-8-2, BOH-CARGO-12-1, BOH-CARGO-6 & FPU-20-1 & FPU-20- 2
OPERATION UNDER UNUSUAL CONDITIONS**

INITIAL SETUP:

FPU Downloaded and Operating

Maintenance Level

Operator/Crew

Personnel Required

Two (plus one supervisor)

OPERATION UNDER UNUSUAL CONDITIONS

This work package provides instructions for the operation of the FPU under unusual conditions. These include adverse weather, nuclear, biological and chemical attack, and emergency blackout conditions.

Operation in Rain and/or Mud

1. Provide an adequate drainage ditch to prevent standing water around the FPU.
2. Secure all accessories and container during extremely harsh rain.

Operation in Hot Weather

1. Use gloves when operating doors during extreme hot conditions to prevent burning hands and fingers.

WARNING



In extreme hot conditions, do not touch metal parts with bare hands.
Severe skin damage may result.

Operation in Snow, Ice, or Extreme Cold

WARNING



In extreme cold conditions, do not touch metal parts with bare hands. Severe skin damage may result.

Fording

The FPU is not watertight. It should never be submerged in any depth of water or material damage may result. When mounted on a trailer or PLS truck, hard-bottom water crossings no deeper than approximately two feet can be forded. When in doubt, refer to Unit Standard Operating Procedures.

Interim Nuclear, Biological, and Chemical (NBC) Decontamination Procedures

WARNING



The FPU is NOT designed for active operations in contaminated NBC Environments. Do not operate the FPU in contaminated NBC environments. If possible cease operation in the FPU system prior to a NBC event and close all doors.

END OF WORK PACKAGE